

*An Online CPD Course  
brought to you by  
CEDengineering.ca*

# **Fundamentals of Single-Base Real-Time GNSS Positioning**

Course No: L06-005  
Credit: 6 PDH

---

Gilbert Gedeon, P.E.

---



Continuing Education and Development, Inc.

P: (877) 322-5800  
[info@cedengineering.ca](mailto:info@cedengineering.ca)

*This course was adapted from the U.S. Department of Commerce, National Oceanic and Atmospheric Administration, “User Guidelines for Single Base Real Time GNSS Positioning”, Version 3.1, April 2014, which is in the public domain.*

## **Table of Contents**

Table of Contents .....	i
Notation and Acronyms .....	ii
I. Introduction .....	1
II. Equipment .....	4
III. RT GNSS Positioning .....	11
IV. Before Beginning Work.....	17
V. Field Procedures.....	27
VI. Further Work in the Office .....	46
VII. Contrast to Real-time Networks (RTN) .....	48
VIII. Best Methods Summary .....	50
References.....	56
Appendix A – Differencing & Ambiguity Resolution.....	59
Appendix B – Adjusting the Circular Vial .....	66

## **Notations and Acronyms**

$\varphi$	Cycles of Carrier Wave
$\Delta$	Difference
$c$	Speed of Light in a Vacuum (299,792.458 km/sec)
$f$	Frequency
$\sigma$	Sigma, One Standard Deviation in a Normal Distribution
$\lambda$	Wavelength
AR	Ambiguity Resolution
ARP	Antenna Reference Point
C/A code	Coarse Acquisition or Clear Acquisition Code
CDMA	Code Division Multiple Access
CORS	Continuously Operating Reference Station(s)
DD	Double Difference
DoD	Department of Defense
DGPS	Differential GPS
ECEF	Earth Centered, Earth Fixed (Coordinates)
FDMA	Frequency Division Multiple Access
G1 to G5	Geomagnetic Storm Categories
GDOP	Geometric Dilution of Precision
GIS	Geographic Information System
GLONASS	Global'naya Navigatsionnaya Sputnikovaya Sistema (Global Orbiting Navigation Satellite System: Russian)
GNSS	Global Navigation Satellite System (Worldwide)
GPS	NAVSTAR Global Positioning System
GPRS	General Packet Radio Service
GRS 80	Geodetic Reference System 1980
GSM	Global System for Mobile Communications
HDOP	Horizontal Dilution of Precision
IP	Internet Protocol
ITRF	International Terrestrial Reference Frame

**Notations and Acronyms (continued)**

L <sub>1</sub>	GPS L Band Carrier Wave at 1575.42 MHz
L <sub>2</sub>	GPS L Band Carrier Wave at 1227.60 MHz
L <sub>5</sub>	GPS L Band Carrier Wave at 1176.45 MHz
L <sub>n</sub>	Narrow Lane frequency combination (L <sub>1</sub> + L <sub>2</sub> )
L <sub>w</sub>	Wide Lane frequency combination (L <sub>1</sub> - L <sub>2</sub> )
MHz	Megahertz (1 million cycles/second)
NAD 83	North American Datum 1983
NAVD 88	North American Vertical Datum 1988
NGS	National Geodetic Survey
NMEA	National Marine Electronics Association
NOAA	National Oceanic and Atmospheric Administration
NSRS	National Spatial Reference System
P code	Precise Code
PCV	Phase Center Variation
PDOP	Position Dilution of Precision
PPM	Part(s) Per Million
PRN	Pseudorandom Noise (or Number)
PZ 90	Parametry Zemli 1990 (Parameters of the Earth 1990 -Russian)
R1 to R5	Radio Blackout Event categories
RDOP	Relative Dilution of Precision
RT	Real-Time Positioning
RTCM	Radio Technical Commission for Maritime Services
RTCM SC-104	RTCM Special Committee 104 (differential positioning)
RTK	Real-Time Kinematic
RTN	Real-Time Network(s)
RMS	Root Mean Square
S1 to S5	Solar Radiation Event categories
S/A	Selective Availability
SIM	Subscriber Identity Module

## **Notations and Acronyms (concluded)**

SPC	State Plane Coordinate(s)
SVN	Space Vehicle Number
SWPC	Space Weather Prediction Center
TCP	Transmission Control Protocol
TDOP	Time Dilution of Precision
TTF	Time To First Fix
UERE	User Equivalent Range Error
UHF	Ultra High Frequency
UTM	Universal Transverse Mercator
VDOP	Vertical Dilution of Precision
VHF	Very High Frequency
WGS 84	World Geodetic System 1984

## **Version History**

### **Draft version**

- Versions 1.0 to 1.9 = original with internal draft editing to April 2008
- Versions 2.0.0 to 2.4.0 = reflects public comments to August 2009
- Versions 3.0.0 to 3.1.1 = reflects AAGS Government Programs Committee comments, author's additions and further public comment - current

### **Released Version**

- Versions 1.0 to 1.1 = approved by NGS Products and Services Committee (PSC) and Executive Steering Committee (ESC), January 2010
- Version 2.0 to 2.1 = text edits and document reformatting, approved by PSC, April 2011
- Version 3.1 (current) = updates, changes to appendices, April, 2014

## **I. Introduction**

These user guidelines are intended to provide a practical method to obtain consistent, accurate three-dimensional positions using classical, single base real-time (RT) techniques. Those practitioners experienced with satellite systems and the elements that affect them might want to just review Chapters V and VIII to see the best methods recommended for precise RT field work. However, in addition to these best methods, and due to the plethora of variables associated with RT positioning, this document is meant to be a source for pertinent background information that the competent RT user should digest and keep in mind when performing high- accuracy positioning. Due to the rapidly changing environment of Global Navigation Satellite System (GNSS) positioning, it is understood that this document will be dynamic and would be best served to remain in digital form. Improvements to GNSS hardware and software, increased wireless communication capabilities, new signals, and additional satellite constellations will yield significantly easier, faster and more accurate RT positioning in the near future. These guidelines are not meant to exclude other accepted practices users have found to produce accurate results, but will augment the basic knowledge base to increase confidence in RT positioning.

Classical (single base) Real-Time Kinematic (RTK) positioning or “RT” positioning as commonly shortened, is a powerful application employing GNSS technology to produce and collect three-dimensional (3-D) positions relative to a fixed (stationary) base station with expected relative accuracies in each coordinate component on the order of a centimeter, using minimal epochs of data collection. Baseline vectors are produced from the antenna phase center (APC) of a stationary base receiver to the APC of the rover antenna using the Earth-Centered, Earth-Fixed (ECEF) X,Y,Z Cartesian coordinates of the World Geodetic System 1984 (WGS 84) Datum, the reference system in which the Department of Defense (DoD) Navstar Global Positioning System (GPS) system broadcast orbits are realized (differential X,Y,Z vectors in other reference frames would be possible if different orbits were used). Current technology may also incorporate the Russian Federation Global’ naya Navigatsionnaya Sputnikovaya Sistema (GLONASS) constellation into the computations, whose orbits are defined in the Parametry Zemli 1990 (Parameters of the Earth 1990- PZ 90.02) datum. The coordinates of the point of interest at the rover position are then obtained by adding the vector (as a difference in Cartesian coordinates) to the station coordinates of the

base antenna, and applying the antenna height above the base station mark and also the height of the rover pole. Usually, the antenna reference point (ARP) is used as a fixed vertical reference. Phase center variation models, including a vertical offset constant, are typically applied in the RT firmware to position the electrical phase center of the antenna which varies by satellite elevation and azimuth.

Because of the variables involved with RT however, the reliability of the positions obtained are much harder to verify than with static or rapid static GNSS positioning. The myriad of variables involved require good knowledge and attention to detail from the field operator. Therefore, experience, science and art are all part of using RT to its best advantage.

RT positioning of important data points cannot be done reliably without some form of redundancy. As has been shown in the NOAA Manual NOS NGS-58 document “GPS Derived Ellipsoid Heights” (Zilkoski, et. al., 1997), and NOAA Manual NOS NGS-59 document “GPS Derived Orthometric Heights” (Zilkoski, et. al., 2005), GNSS positions can be expected to be more accurate when one position obtained at a particular time of day is averaged with a redundant position obtained at a time staggered by three or four hours (and thus with different satellite geometry and multipath effects). The different satellite geometry commonly produces different results at the staggered times. The position can be accurately obtained by simple averaging of the two (or more) positions thus obtained. Redundant observations are covered in the Accuracy Classes of the Field Procedures section, where most of the RT Check List items found below, are also discussed.

An appreciation of the many variables involved with RT positioning will result in better planning and field procedures. In the coming years, when a modernized GPS constellation and a more robust GLONASS constellation will be joined by Compass/Beidou (China), Galileo (European Union) and possibly other GNSS, there could be in excess of 115 satellites accessible. Accurate, repeatable positions could become much easier at that time.

Note: The term “user” in this document refers to a person who uses RT GNSS surveying techniques and/or analyzes RT GNSS data to determine three-dimensional position coordinates and metadata using RT methods.

Outside of the Summary sections, important concepts or procedures are set in bolded red text, as in the following example:

***Redundancy is critical for important point positions using RT.***

## **Typical RT Checklist**

Look for these terms and concepts in the guidelines. Knowledge of these are necessary for expertise at the rover:

- DOP varieties
- Multipath
- Baseline RMS
- Number of satellites
- Elevation mask (or cut-off angle)
- Base accuracy – datum level, local level
- Base security
- Redundancy, redundancy, redundancy
- PPM – iono, tropo models, orbit errors
- Space weather – “G”, “S”, “R” levels
- Geoid quality
- Constraining passive monuments
- Bubble adjustment
- Latency, update rate
- Fixed and float solutions

## II. Equipment

A typical current-configured, user-operated field RT setup might use the following equipment for wireless communication:

### Base:

- 1 - Dual frequency GPS + GLONASS GNSS base receiver
  - 1- Dual frequency GPS + GLONASS GNSS high quality antenna capable of multipath rejection characteristics traditionally found in ground plane and/or choke ring antennas
  - 1- GNSS antenna cable
  - 1- Fixed height tripod, weights for the legs on long occupations
  - 1- lead acid battery with power leads to receiver. (Note: typical power input level on GNSS receivers is in the range of 10.5 volts – 28 volts. Users frequently use a 12 volt lawn tractor battery to keep the carrying weight down.)
- Data transmission can be done by one of the following:

Common communication setups require a Broadcast Radio:

UHF (0.3 GHz – 3.0 GHz) = 25 to 35 watt base radio, Federal Communications Commission (FCC) licensed (required with severe non-compliance penalties), two to four channels (ten or more channels recommended), lead acid battery, power cable, antenna mast, antenna tripod or mount for base tripod, data cable. Range is typically 5 to 8 km (3 miles to 5 miles) in non-rural areas.

***Regardless of the type of external battery used, it should supply at least 12 volts and should be fully charged. An underpowered battery can severely limit communication range.***

### Important FCC Narrowbanding information for VHF and UHF radio users:

<http://transition.fcc.gov/pshs/public-safety-spectrum/narrowbanding.html>

**Note:** A full-size whip antenna option will enhance communications. It can produce a higher signal to noise ratio and, therefore, a longer usable communication range. Also, to greatly extend range in linear surveys (highways, transmission lines, etc.), a directional antenna for the broadcast radio should be considered.

***The base broadcast radio antenna should be raised to the maximum height possible.***

Studies have shown that an increase in antenna height from 5' to 20' will increase the broadcast range from 5 to 11 miles. The study shows a doubling in antenna height will increase the range by 40%. However, any height over 25' should use a low-loss cable.

Another option for communication is by a TCP/IP data connection:

CDMA (SIM/Cell/CF card) = wireless data modem, card or phone with static IP address, battery pack and cable, data cable from receiver or Bluetooth, whip antenna. With the availability of cell coverage, the range is limited only by the ability to resolve the ambiguities.

**Rover:**

1 Dual frequency GPS + GLONASS GNSS integrated receiver/antenna, internal batteries

1 Carbon fiber rover pole (two sections fixed height), circular level vial

**Note:** the condition of the rover pole should be straight and not warped or bent in any manner.

1 Rover pole bipod or tripod with quick release legs

1 Data collector, internal battery and pole mount bracket

1 Data link between Receiver and Data Collector, encompassing:

a) Cable

OR

b) Bluetooth wireless connection

Data Reception by one of the following:

a) Internal UHF radio (receive only, paired to base frequency) with whip antenna

OR

b) CDMA/SIM/Cell/CF card = wireless data modem with *static* IP address, battery pack and cable, data cable from receiver or Bluetooth, whip antenna.

**Note:** Spread spectrum radios can be used for small project areas. These do not require a FCC license, but the range is relatively limited, in many cases to only line of sight. Various peripherals, such as laser range finders, inclinometers, electronic compasses, etc. are also available and may prove useful for various applications.

**A Note on Single Frequency RT:** Single frequency GPS RT *is* possible. While this application would incur reduced hardware expense, it also requires mean longer initialization times, no on-the-fly initialization, less robustness, shorter baselines and would preclude frequency combinations (such as the L<sub>3</sub>, iono-free combination). Thus, L<sub>1</sub> RT positioning is not a preferred solution and will not be further addressed as a unique application in this document. The general principles and best methods for RT field work still apply, however, and should be applied for L<sub>1</sub> work as well.

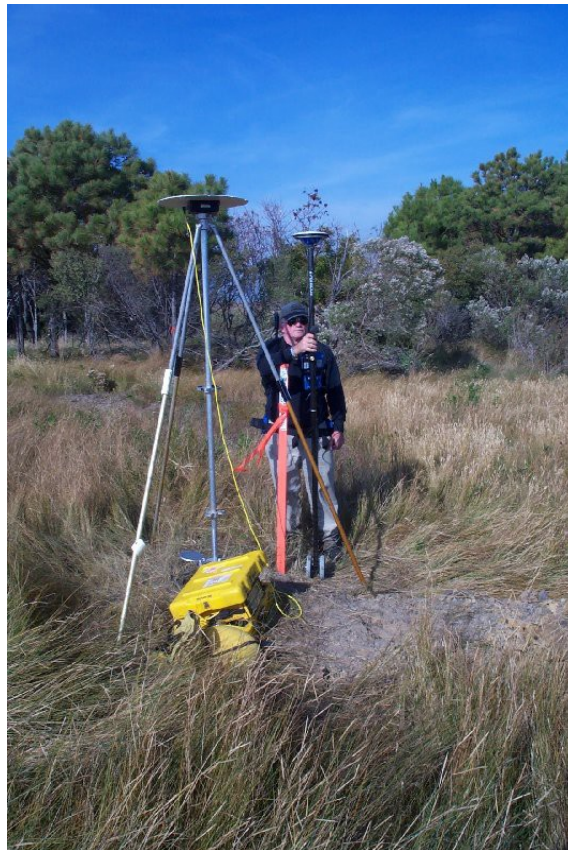

*Diagram II-1. The base station should use a ground plane, choke ring, or a current high quality, geodetic, multipath rejecting antenna while the rover typically operates with a smaller antenna (usually integrated with the rover receiver) for ease of use.*

***Adjust the base and rover circular level vial before every campaign (See Appendix B).***

***As a good practice or if the circular level vial is not adjusted, it is still possible to eliminate the possible plumbing error by taking two locations on a point with the rover pole rotated 180° between each location.***

### Typical Base UHF Radio RT Set-ups

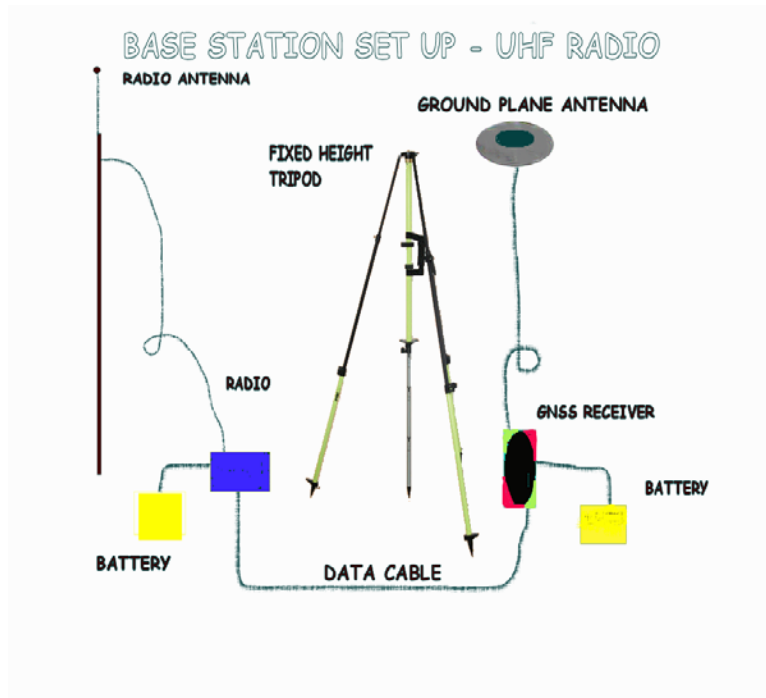

Diagram II-2: Typical UHF Radio Base Set Up. The radio antenna should be elevated to the greatest extent possible to facilitate broadcast range.

### ROVER SET UP - INTERNAL RADIO

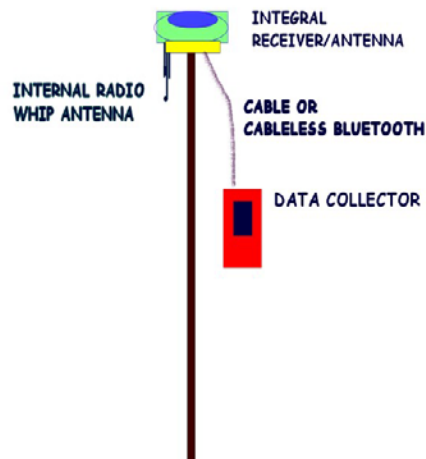

Diagram II-3: Typical UHF Radio Rover Set Up (Receive-Only)

Typical Code Division Multiple Access (CDMA) data modems (*see Diagrams II-4 and II-5*) and flash media modems (*see Diagram II-6*) require the user to subscribe to a wireless phone service, allowing for use of the wireless service providers' cell towers for Internet connectivity to send and receive data over much longer distances than with UHF broadcasts. These would replace the UHF radio configuration for the base and rover shown in Diagrams II-2 and II-3. Data services are available by monthly subscriptions through several carriers and vary by geographical region. The user must contact the carrier to set up a data service. Typically, rates vary by data usage, rather than by time. Data are sent by the base via a TCP/IP address to the rover. The rover then performs the correction and difference calculations and displays the results with no loss of usable latency—typically totaling fewer than two or three seconds to position display (*see this topic in Chapter V.*). These systems enable virtually unlimited range from the base station; however, in a scenario where only one base station is used, the ability to resolve ambiguities at a common epoch and the part per million errors limit accuracy range in most cases. The fact that atmospheric conditions can vary from base position to rover position, particularly at extended ranges, and the fact that the rover uses the conditions broadcast from the base, cause the range and phase corrections to be improperly applied, contributing to positional error. CDMA modems can be used effectively at extended ranges in RT networks (RTN) where the atmospheric and orbital errors are interpolated to the site of the rover. Cell phones and stand-alone Subscriber Identity Module (SIM) cards (*see Diagram II-7*) in Global System for Mobile Communication (GSM) networks use similar methods as CDMA data modems to send data. Many current GNSS receivers have integrated communication modules.

Rather than communicating with a dynamic address, as is the case in many Internet scenarios, static *IP* addresses provide a reliable connection and are the recommended communication link configuration. Static addresses are linked with the same address each time the data modems connect and are not in use when there is no connection. However, there is a cost premium for this service. Contact the wireless service provider for the actual rates.



Diagram II-4: CDMA Modem Front Panel (Courtesy of AirLink Comm.)



- Tx (transmit) and Rx (receive) - Lights will flash as data is transferred to and from the Raven on the remote network.
- RSSI(signal level) - Light shows the strength of the signal and may be nearly solid (strong signal) or flashing (weaker signal). A slow flash indicates a very weak signal.
- Reg (registration) - Indicates the Raven has acquired an IP from Verizon.
- Chan (channel) - Indicates the modem has acquired a network channel.
- Link - Indicates a successful connection to the cellular network.
- Pwr (power) - Indicates the power adapter is connected and there is power getting to the modem.

**Note the data transm**

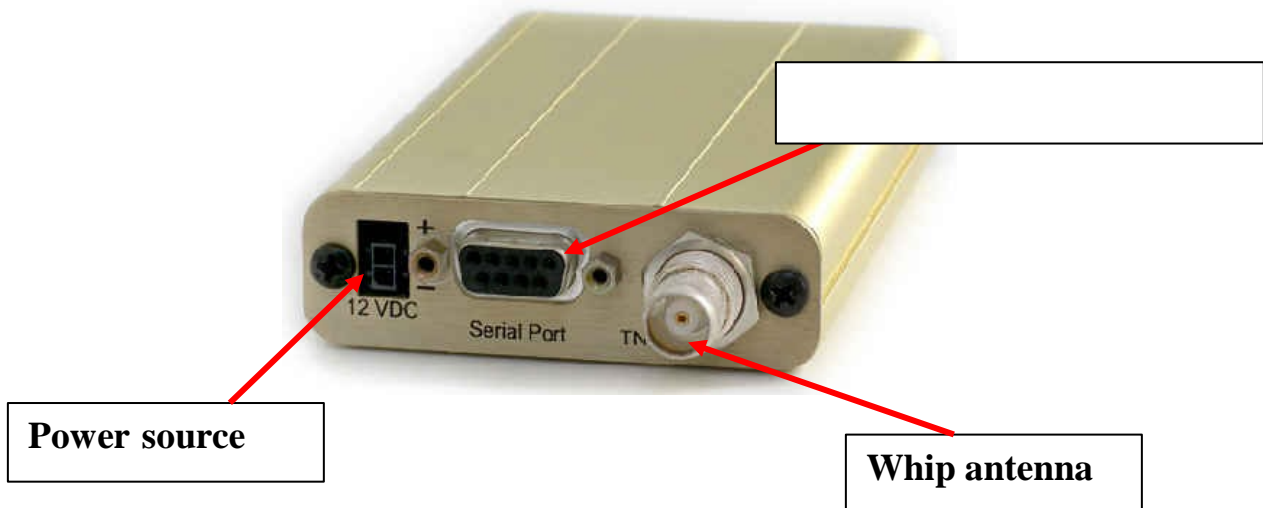

Diagram II-5: CDMA Data Modem Back Panel



Diagram II-6: Examples of Compact Flash Modems



Diagram II-7: Examples of SIM Cards used in GSM/GPRS format Data Service

### III. RT GNSS Positioning

RT positioning relies on differences in carrier phase cycles, in each available frequency to each satellite, between the base station and rover at common epochs of time. Two L-band frequencies,  $L_1$  and  $L_2$ , are currently available to GPS users at this writing with a third frequency,  $L_5$ , being added in the Block II-F and Block III satellites. A summary of the code and carrier phases is given in **Table III-1**. The three frequencies ( $L_1$ ,  $L_2$  and  $L_5$ ) are derived from a fundamental frequency of 10.23 MHz, so that:

$$L_1 = 1575.42 \text{ MHz} = 154 \times 10.23 \text{ MHz}$$

$$L_2 = 1227.6 \text{ MHz} = 120 \times 10.23 \text{ MHz}$$

and

$$L_5 = 1176.45 \text{ MHz} = 115 \times 10.23 \text{ MHz}$$

The wavelengths of the carriers are:

$$\lambda_1 = 19.03 \text{ cm}$$

$$\lambda_2 = 24.42 \text{ cm}$$

$$\lambda_5 = 25.48 \text{ cm}$$

FREQUENCY LABEL	FREQUENCY	CONTENTS
<b>L<sub>1</sub></b>	1575.42 MHz	COARSE ACQUISITION (C/A) CODE, PRECISE CODE [P(Y)], NAVIGATION MESSAGE
<b>L<sub>2</sub></b>	1227.60 MHz	PRECISE CODE [P(Y)], L <sub>2</sub> C CIVIL CODE ON BLOCK II-M AND NEWER
<b>L<sub>5</sub></b>	1176.45 MHz	CIVILIAN SAFETY OF LIFE (SoL-PROTECTED AERONAUTICAL, NO INTERFERENCE), BLOCK II-F AND BLOCK III

*Table III-1: Civilian GPS L band frequencies. L5 is in Block II-F and future Block III Satellites.*

In classical single base RT positioning, most of the error budget (*see Table III-2*) is addressed by simply assuming that atmospheric conditions are identical at the base and rover. The rest are usually eliminated using double differencing techniques. The User Equivalent Range Error (UERE) is the total of the uncorrected errors expected with normal conditions.

*(See Appendix A for graphics and the GPS observable equations describing the differencing process.)*

<b>ERROR</b>	<b>VALUE</b>
Ionosphere	4.0 METERS
Ephemeris	2.1 METERS
Clock	2.1 METERS
Troposphere	0.7 METERS
Receiver	0.5 METERS
Multipath	1.0 METERS
<b>TOTAL</b>	<b>10.4 METERS</b>
<b>UNCORRELATED ERROR</b>	<b>5.15 m (square root of sum of errors squared)</b>

*Table III-2. The GPS Error Budget. Errors are as given for the GNSS antenna zero zenith angle. Clock and hardware errors are eliminated with differencing, while some modeling can be done for the Ionospheric and Tropospheric errors. Generally, the conditions are considered to cancel as they are relative to both base and rover receivers. Note: 1 nanosecond of time error translates to 30 cm in range error.*

GLONASS can augment the functionality of GPS. GLONASS is an independent GNSS, but when combined with GPS, provides additional satellite visibility and redundancy. Presently, GLONASS satellites transmit a common code on different frequencies, referred to as frequency division multiple access (FDMA) technology. This is in contrast to the GPS CDMA format of common frequencies with unique satellite codes. Besides adding to the total available satellites, including GLONASS usually increases geometrical strength. The redundancy increases the speed and reliability of the ambiguity resolution process and can give fixes in traditionally bad GPS conditions, such as urban canyons and road rights-of-way between tree canopy rows. However, GPS time is not synchronized with GLONASS time (and the GLONASS constellation orbits are broadcast in PZ 90). Thus, the receiver clock has two time-related unknowns: the difference with GPS time, and the difference with GLONASS time. These two clock terms, plus the three X,Y,Z position unknowns, are solved by having at least five satellites in view, with two being GLONASS. GLONASS satellite

ephemerides used by the RT survey are transformed from PZ 90 to WGS 84. Although the receivers correctly tag the partial wavelength after locking on to the satellites, to correctly position the rover the initial unknown number of whole carrier phase cycles at that epoch must be resolved. Subsequently, the change in phase is maintained to differentially position the rover. Loss of lock must be accounted for in order to resolve the new integer phase count. Many techniques exist to do this calculation and each GNSS software/firmware manufacturer has proprietary algorithms that are not freely disseminated. Some basic, proven techniques used in various calculation iterations are: using combinations of frequencies as with wide lane, narrow lane, and iono-free, Kalman filtering, and single/double/triple differencing. These will be briefly discussed in this section to give the user an appreciation of the complexity of calculations being done at the rover receiver and being displayed in the data collector, initially in typically under 10 seconds and with only a second (or perhaps up to three seconds) of latency in continuing positioning. (See Diagram III-1.) The results of “fixing” the initial number of integer wavelengths, from each satellite on each frequency for a common epoch of data, and the relative ECEF X,Y,Z position vector from the base to the rover, are obtained by using least squares adjustments to apply the differences to the base coordinates. As such, the geometry of the solution is simply an inverse from the base to the rover, based on computations to each satellite on each frequency, and referenced to the ECEF WGS 84 origin from the base and rover antennas. Transformations to other datums, such as North American Datum 1983 (NAD 83), are then performed using established transformation parameters. Typically, the user will work with a display of a projection, such as stipulated for the State Plane Coordinate Systems (SPC), or a local variation thereof, after localizing to passive local monumentation (also known as a calibration). (See Section V. for a discussion on localization.)

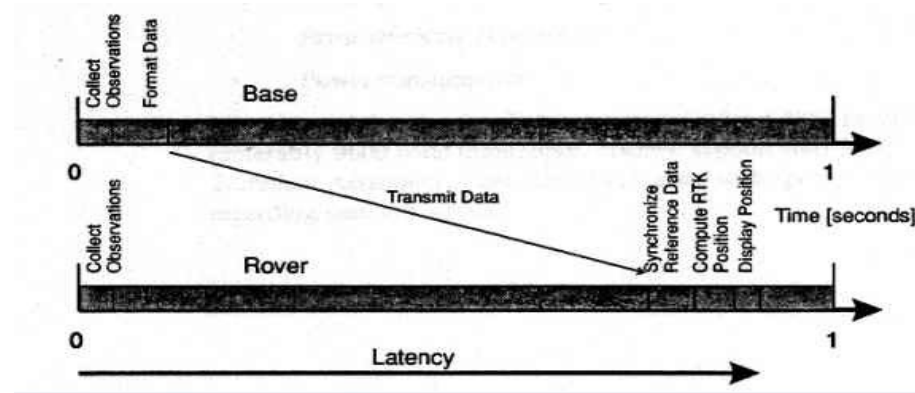

Diagram III-1: Data Flow Latency Concept

Briefly, an RT positioning system includes base and rover GNSS units connected by a wireless data link. The rover unit is typically moved to points of interest during a survey session, while the base station remains over a fixed, and usually known, location.

***It is possible to perform an accurate RT session from an autonomous-positioned base station point, if the correct position can be introduced to the project in the data collector or in the office software later.***

The autonomous base position is usually taken by selecting the position displayed after the coordinates “settle down” or start to show less variation from interval to interval—typically 30 seconds or less. Since the rover-generated positions are the result of a vector relative to the base station, the translation of the autonomous base position to a known position simply shifts the 3-D vectors in the initial X, Y, Z ECEF coordinates to originate at the new X,Y, Z ECEF coordinates, and the field firmware or office software updates the RT positions accordingly, displaying the data in the user selected projection. For local projects, rotation about the axes is not an issue. The base antenna should be located to optimize a clear view of the sky (Meyer, et al 2002).

***In fact, it is much better to establish a new, completely open sky view site for the base than it is to try to occupy an existing reliable, well known monument with a somewhat obscured sky view.***

Processing is based on common satellites, and the fact that the rover will usually be in varying conditions of obstruction to the sky means it will not always be locked on the total available satellites. Therefore, the base antenna site must be optimized to look at all the possible satellites. The rover antenna will often be obstructed by trees or buildings in such a way that the signals are interrupted, and a re-initialization process is performed. Each rover project site could conceivably use a different subset of the total in-view constellation, because of the obstructions.

Explained in an extremely general way, the rover might progress through the following algorithms in an iterative process to get a fixed ambiguity resolution. (*Also, see Diagram III-2*):

1. Use pseudorange and carrier phase observables to estimate integer ambiguities. Multipath can cause pseudorange noise which will limit this technique. Typically, this can achieve sub meter positions. Kalman filtering or recursive least square selection sets can aid in narrowing the selection set.
2. Achieve a differential float ambiguity solution (this is a decimal carrier phase count, rather than a whole number of cycles). Estimates are run through measurement noise reduction filters.

Differencing reduces or eliminates satellite clock errors, receiver clock errors, satellite hardware errors, receiver hardware errors, and cycle slips.

3. Integer ambiguity search is started. Frequency combinations narrow the field of candidates. The more satellites, the more robust the integer search:

The wide lane wavelength,  $L_w$ , is the difference of the two GPS frequencies,  $L_1 - L_2$ . So, “c” (speed of light)  $\div$  (1575.42 MHz – 1227.60 MHz) or  $299,792.458 \text{ Km/sec} \div 347.82 \text{ MHz} = 0.862 \text{ m}$  effective wavelength. This longer wavelength is more readily resolved compared to the  $L_1$  frequency wavelength of 0.190 m, or  $L_2$  frequency wavelength of 0.240 m. However, the wide lane combination adds about 6 times the “noise” to the observable, and about 1.28 times to the ionospheric effect.

The narrow lane wavelength,  $L_n$ , is the sum of the two GPS frequencies,  $L_1 + L_2$ .

So, c (speed of light)  $\div$  (1575.42 MHz + 1227.60 MHz) or  $299,792.458 \text{ Km/sec} \div 2803.02 \text{ MHz} = 0.107 \text{ m}$  wavelength. The narrow wavelength makes the ambiguity hard to resolve for this combination, but helps detect cycle slips, compute Doppler frequencies and to validate the integer resolution.

The “Ionosphere free” or, as commonly called, “L3” linear combination of the frequencies can eliminate most of the ionosphere error (phase advance, group code delay) in the observables but should not be relied on for the final solution for short baselines because of the additional noise introduced into the solution. The time delay of the signal is proportional to the inverse of the frequency squared; that is, higher frequencies are less affected by the ionosphere, and hence the ionospheric time delay for  $L_1$  observations (1575.42MHz) is less than for  $L_2$  observations (1227.60MHz). The L3 wavelength is 48.44 m. However, the  $L_2$  ionospheric error effect is approximately 1.646 times that of  $L_1$  and noise is also increased. Still, double differenced L3 combinations can provide the most accurate solution on extended baseline lengths. Some GNSS manufacturers even set this switchover to the L3 solution at 5 km.

4. The integer ambiguity is fixed and initialization of sub-centimeter level positioning begins. Covariance matrices can be stored in certain rover configurations to enable post campaign adjustment in the office software (assuming redundancy or baseline connections).

Continual fixed ambiguity analysis is performed at the rover to verify the integer count. Ratio of the best to next best solution is evaluated. It is interesting to note that the confidence of a correct integer fix from an on-the fly-initialization is stated by most GNSS hardware manufacturers at

99.9 percent (even though an incorrect set of integer ambiguities can appear to the layman to be a better statistical choice!). RMS values of the solution and vector are produced. Once initialized, a subsequent loss of initialization new integer search is considerably enhanced when two or more satellites have been continuously tracked throughout. One or two surviving double-differenced integers bridge over the loss of initialization. This then significantly reduces the number of potential integer combinations and speeds a final integer solution, whereas complete loss of lock starts the ambiguity resolution process over again at step 1.

5. Triple differences and narrow lane frequency combinations can be used to detect cycle slips.

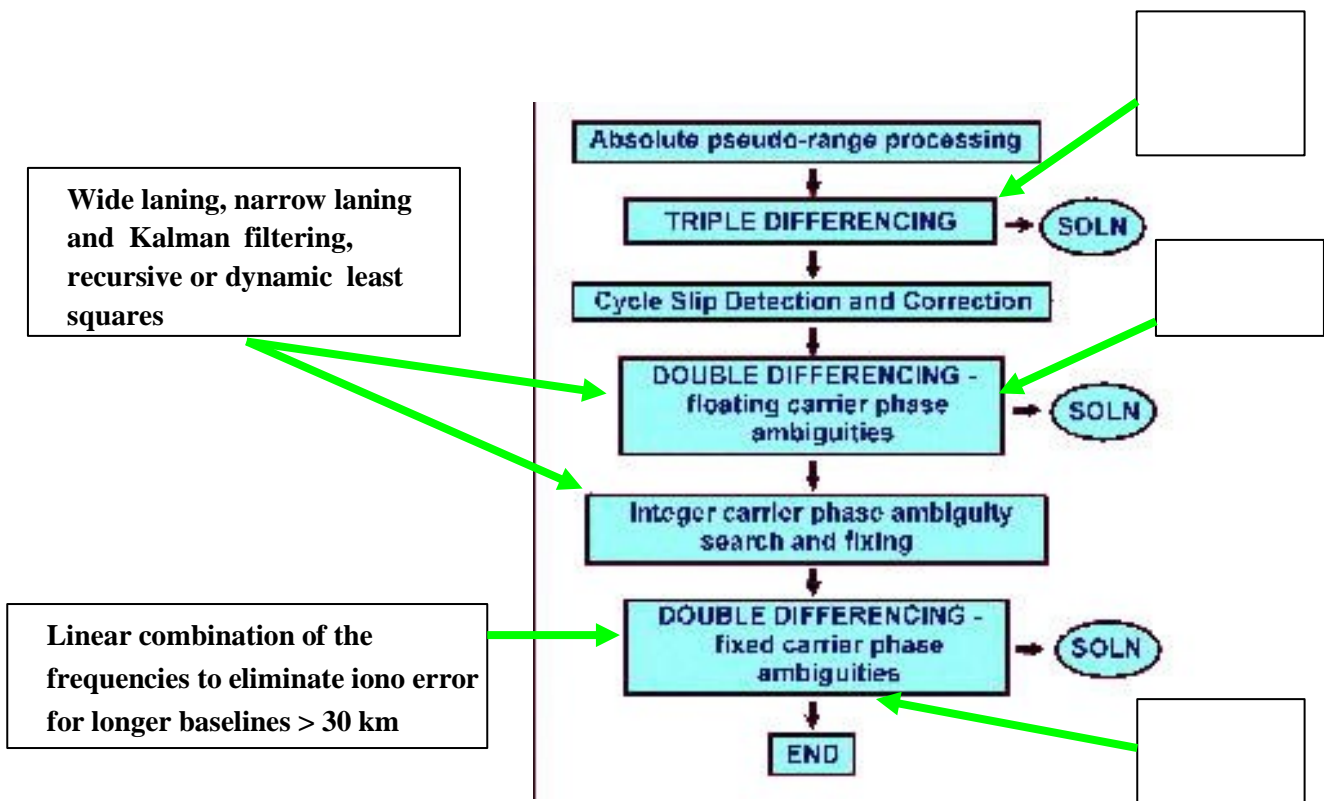

Diagram III-2 – General Flow of Ambiguity Resolution [graphic: Rizos (1999)]

(See Appendix A for further discussion on differencing and ambiguity resolution.)

## IV. Before Beginning Work

An awareness of the expected field conditions can help produce successful campaigns. Although the conditions at all rover locations cannot be known beforehand—especially for multipath conditions and obstructions—satellite availability and geometry, space weather, and atmospheric conditions can be assessed. Therefore, the following background information is provided to educate the RT user as to the many elements that are involved with accurate positioning.

All major GNSS hardware and software providers include a mission planning tool or module charting the sky plot and path of the satellites, the number of satellites and the different DOP across a time line (*see Charts IV-1, 2 and 3*). Additionally, elevation masks and obstructions can be added to give a realistic picture of the conditions at the base location. The user should expect that these would be the optimum conditions and those that the rover will experience will be less than ideal. For current satellite outages, the U.S. Coast Guard sends out a Notice Advisory to Navstar Users (NANU). Users can subscribe to this free mailing at:

<http://navcen.uscg.gov/?pageName=listServerForm>

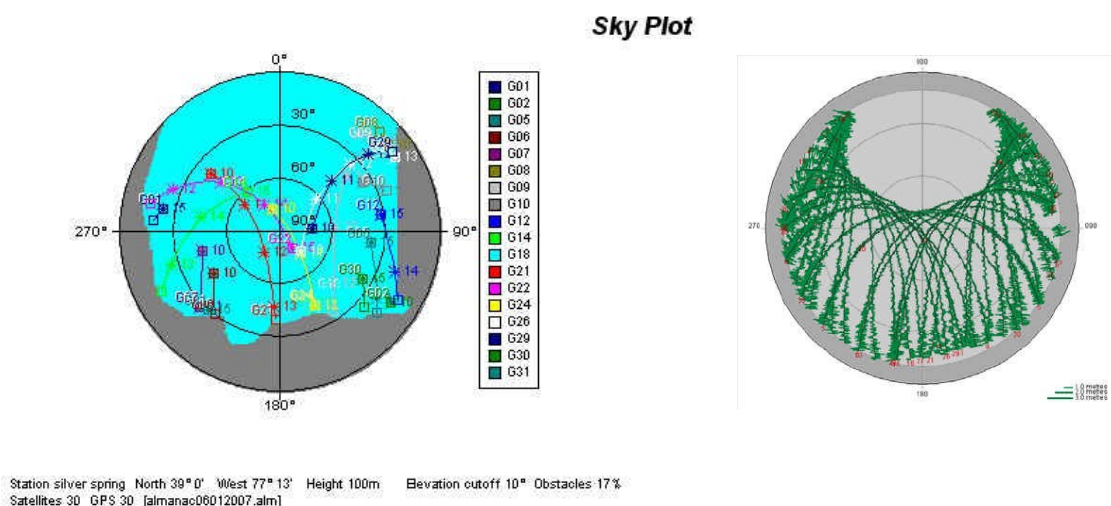

Chart IV-1: Typical Satellite Sky Plots, with and without Site Obstructions

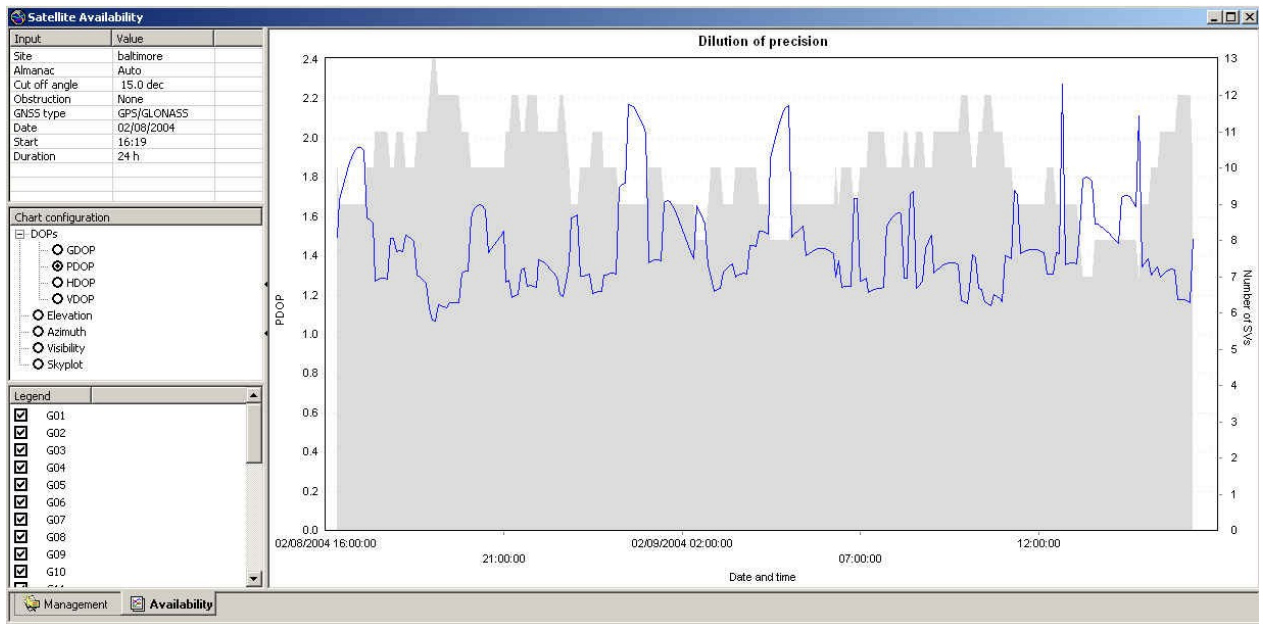

Chart IV-2: Satellite Availability and PDOP Charted Together. (Blue line is PDOP.)

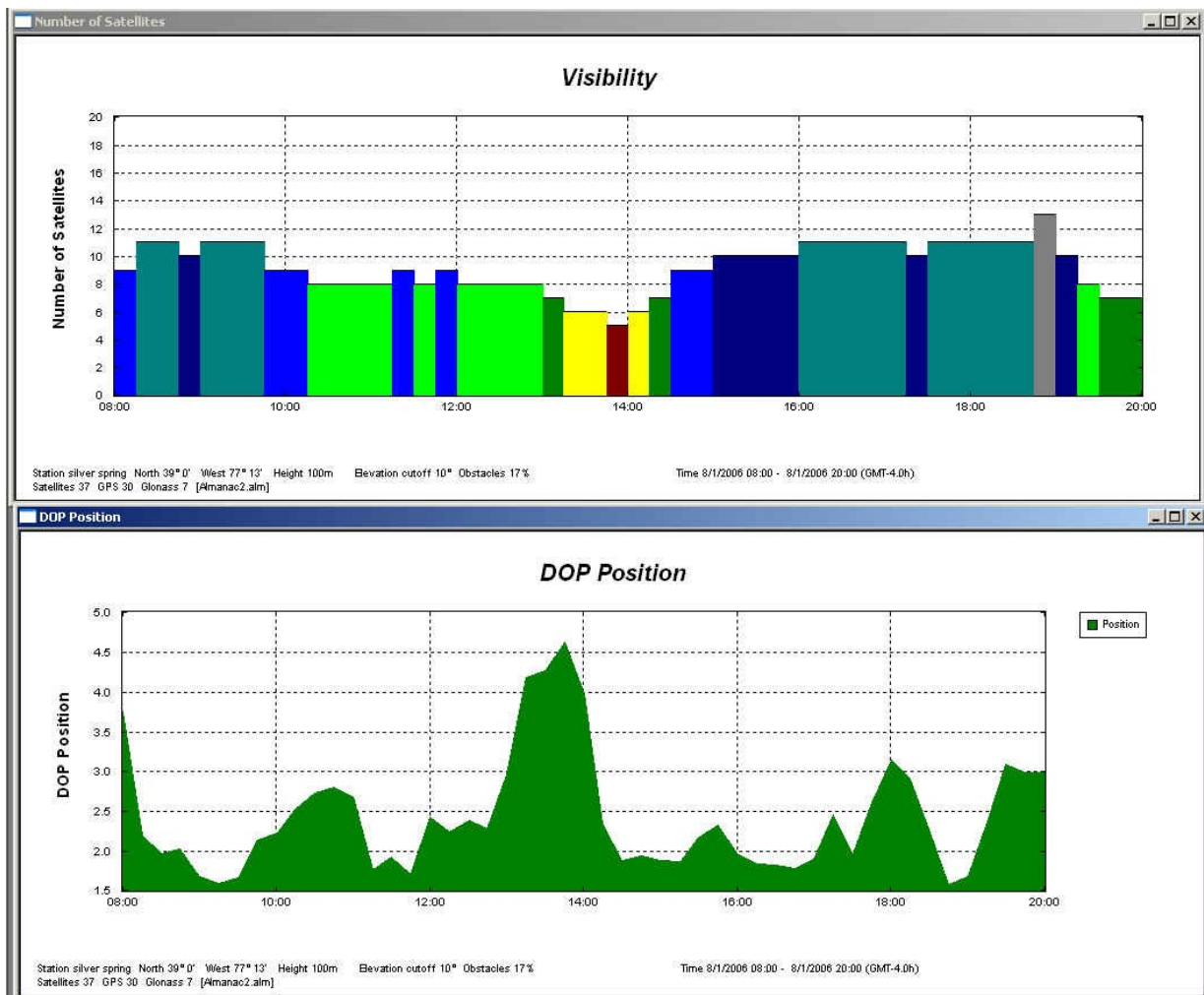

Chart IV-3: Satellite Availability and PDOP—Separate Graphs—Using Obstructions

```
Message: 1
Date: Mon, 27 Aug 2007 12:55:59 -0400
From: "TIS-PF-NISWS" <TIS-PF-NISWS@uscg.mil>
Subject: New NANU 2007103
To: <nanu@cglis.uscg.mil>
Message-ID:
<CA7D54DE6D7AE7479D58F1E552661EAA12ACE5@tis-exmb-m-001a.main.ads.uscg.mil>

Content-Type: text/plain; charset="us-ascii"

NOTICE ADVISORY TO NAVSTAR USERS (NANU) 2007103
SUBJ: SVN54 (PRN18) FORECAST OUTAGE JDAY 243/0130 - JDAY 243/0330
1. NANU TYPE: FCSTMX
   NANU NUMBER: 2007103
   NANU DTG: 271632Z AUG 2007
   REFERENCE NANU: N/A
   REF NANU DTG: N/A
   SVN: 54
   PRN: 18
   START JDAY: 243
   START TIME ZULU: 0130
   START CALENDAR DATE: 31 AUG 2007
   STOP JDAY: 243
   STOP TIME ZULU: 0330
   STOP CALENDAR DATE: 31 AUG 2007

2. CONDITION: GPS SATELLITE SVN54 (PRN18) WILL BE UNUSABLE ON JDAY 243
   (31 AUG 2007) BEGINNING 0130 ZULU UNTIL JDAY 243 (31 AUG 2007)
   ENDING 0330 ZULU.

3. POC: CIVILIAN - NAVCEN AT 703-313-5900, HTTP://WWW.NAVCEN.USCG.GOV
   MILITARY - GPS OPERATIONS CENTER at HTTP://GPS.AFSPC.AF.MIL/GPSOC,
   DSN 560-2541,
   COMM 719-567-2541, gps\_support@schriever.af.mil,
   HTTP://gps.afspc.af.mil/gps
   MILITARY ALTERNATE - JOINT SPACE OPERATIONS CENTER, DSN 276-9994,
   COMM 805-606-9994, JSPOCCOMBATOPS@VANDENBERG.AF.MIL
```

Figure IV-1: Typical body of a “NANU” message

## Atmospheric Errors

Disturbances and variations in the atmosphere can affect RT accuracy and integrity to the extent of making the solution too inaccurate for surveying and engineering applications as well as preventing data link communication between the base station and the rover. Atmospheric conditions can vary in relatively small geographic regions as well as in short spans of time. The two layers that are commonly modeled are broadly categorized as the ionosphere and troposphere. Charged particles in the ionosphere slow down and refract radio signals. It is a dispersive medium in that it affects different frequencies in a correlation to their wavelengths. The delay can actually be calculated because the rate of slowing is inversely proportional to the square of the frequency ( $1/f^2$ ). Additionally, the “weather” in the troposphere refracts radio waves and the water vapor slows them down (wet delay), but not at the same rate as the

ionosphere. It is a non-dispersive medium because it affects all frequencies the same, but is site specific (or “geometrical”). So, the ionospheric error is related to the signals’ frequencies from the satellites and the effect on each frequency’s path , while the tropospheric delay is site specific to the wet and dry weather overhead in the lowest layer of the atmosphere. (See Figure IV-2 for the graphic representation of this phenomenon.)

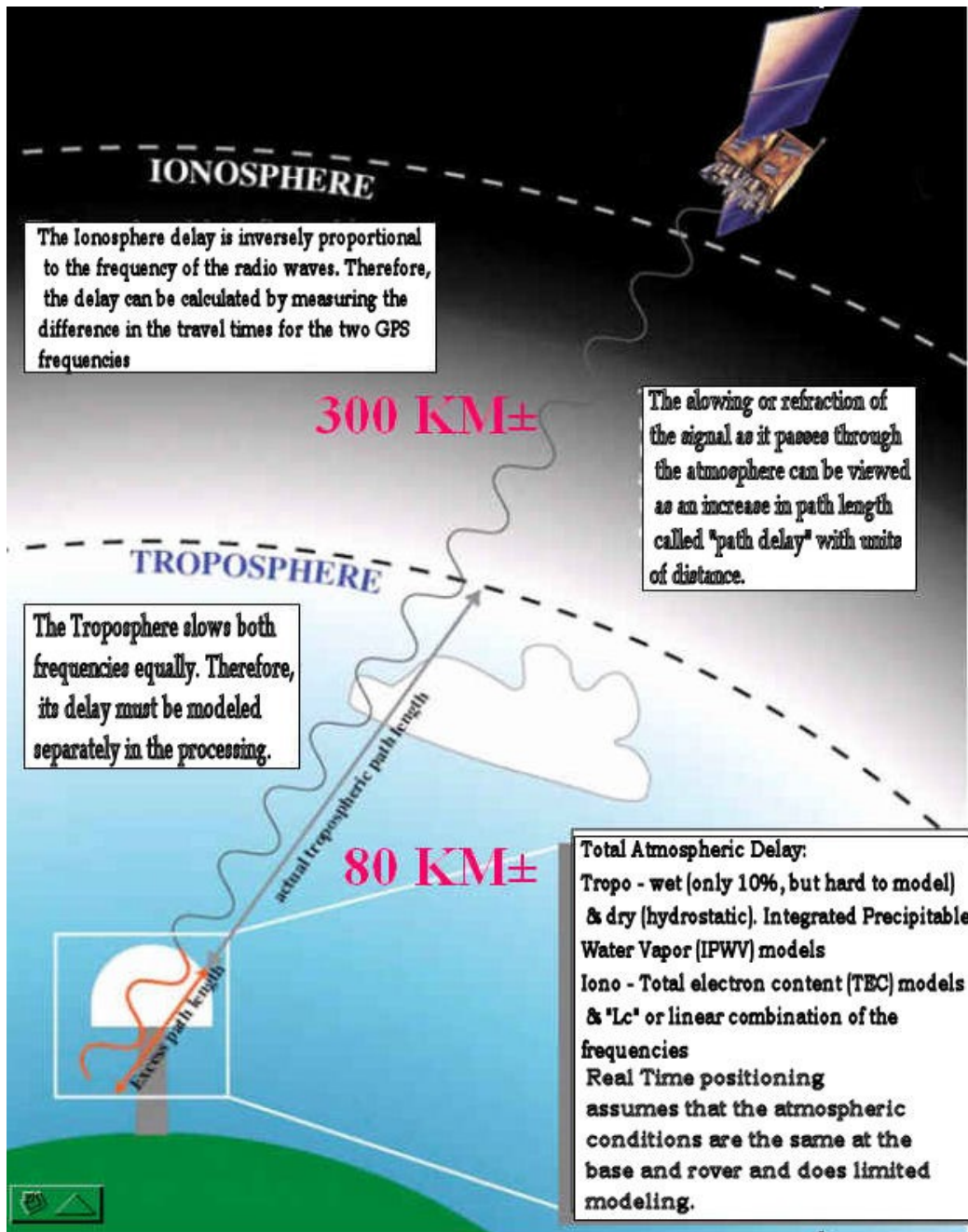

Figure IV-2: Atmospheric Induced Refraction and Delays to the Code and Carrier

Unlike networked solutions for RT positioning, in classical (single base) RT positioning there is minimal atmospheric modeling because it is assumed that both the base station and the rover are experiencing nearly identical atmospheric conditions. Therefore, the delays will be relative to both and would not adversely affect the baseline between them as long as baseline distances are kept relatively short ( $\leq 20$  km) so that atmospheric conditions are not expected to differ between base and rover. For this reason, the rover computes the phase differencing corrections for the observables (each satellite and each frequency) at its position using the observables collected at the base as applied to inverse of the base position to the satellite(s) position (both “known” in ECEF, XYZ). However, a correct ambiguity resolution must be achieved to provide centimeter-level precision. Atmospheric conditions can cause enough signal “noise” to prevent initialization or, worse, can result in an incorrect ambiguity resolution. Additionally, moderate to extreme levels of space storm events as shown on the NOAA Space Weather Prediction Center (SWPC) Space Weather Scales (see link on p.18) could cause poor, intermittent or loss of, radio or wireless communication.

### **Ionospheric Error Discussion**

Sunspots (emerging strong magnetic fields) are the prime indicators of solar activity contributing to increased ionospheric (and possibly tropospheric) disturbance. They are relatively predictable and run in approximately 11-year cycles. The last minimum was in 2006/2007 and the next maximum is expected around 2013. During an interval encompassing the solar maximum, users can expect inability to initialize, loss of satellite communications, loss of wireless connections and radio blackouts, perhaps in random areas and time spans. Therefore, it is important to understand these conditions. The charged particles in the ionosphere affect radio waves proportional to the "total electron content" (TEC) along the wave path. TEC is the total number of free electrons along the path between the satellite and GNSS receiver. In addition, TEC varies with the changes of solar and geomagnetic conditions during the day, with geographic location and with season. As the sunspot number scale increases to the next solar maximum, the impact on GNSS signals will increase, resulting in more problems even at mid-latitudes which are typically not present during the benign times of the cycle. (See Figure IV-3 for the plot of the immediate past, present and predicted solar cycle.)

The following is a summary of space weather conditions and how they may impact RT users as extracted from NOAA's SWPC. The SWPC provides warnings in three different categories: Geomagnetic Storm, Solar Radiation Storm and Radio Blackout. Each of these has a range from mild to severe, such as G1(mild) through G5(severe), and S1-S5 and R1-R5 inclusive.

See <http://www.swpc.noaa.gov/NOAAscales/index.html#SolarRadiationStorms> for the associated tables to explain the following categories:

**1. Geomagnetic Storms:** disturbances in the geomagnetic field caused by gusts in the solar wind (the outward flux of solar particles and magnetic fields from the sun) that blows by Earth. May affect satellite orientation, orbital information, broadcast ephemeris, communication, may cause surface charging. May cause inability to initialize for the GNSS user and radio problems.

***Recommendations: Do not try to perform RT during level G3 - G5 storm events.***

**2. Solar Radiation Storms:** Elevated levels of radiation that occur when the numbers of energetic particles increase. Strong to extreme storms may impact satellite operations, orientation and communication. Degraded, intermittent or loss of radio communication in the northern regions are possible. May impact the noise level at the receiver degrading precision.

***Recommendations: Do not try to perform RT during level S4 - S5 storm events.***

**3. Radio Blackouts:** disturbances of the ionosphere caused by X-ray emissions from the Sun. Strong to Extreme storms may affect satellite signal reception. May cause intermittent, degraded or loss of radio communication. May increase noise at the receiver causing degraded precision.

***Recommendations: Do not try to perform RT during level R3 - R5 storm events. Be aware of possible radio problems at level R2 storm events.***

## The Solar Cycle in Sunspot Number

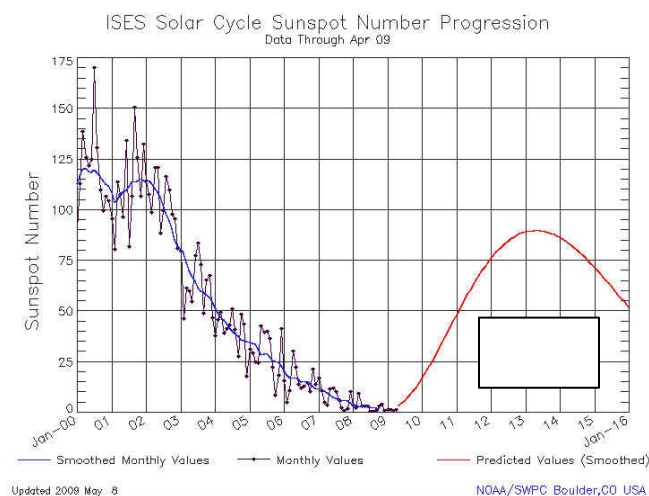
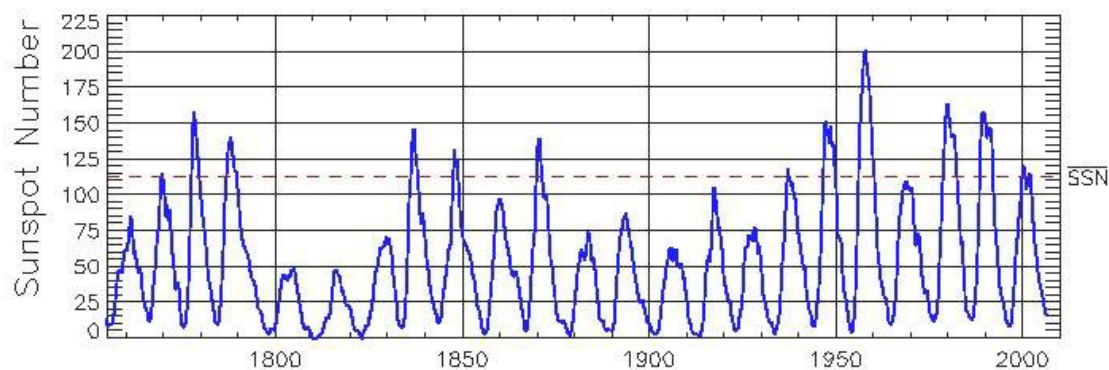

Figure IV-3: Previous Solar Sunspot Activity and the Expected Solar Maximum in 2013 +/-

The SWPC will e-mail a number of user selected space weather updates, warnings, alerts, predictions and summaries. These can be viewed before committing to field operations. Those interested should submit the requests from the SWPC web site as referenced above. However, it must be remembered that conditions change rapidly and cannot always be predicted, especially short term. The user can be aware of these conditions if field problems arise so that error sources can be known and addressed. Re-observation at a later time may be necessary. Two reports that contain forecasts are:

The Geophysical Alert Message (WWV). (See Figure IV-4)

The Report on Solar Geophysical Activity (RSGA). (See Figure IV-5)

```
:Product: Geophysical Alert Message www.txt
:Issued: 2007 Aug 07 0300 UTC
# Prepared by the US Dept. of Commerce, NOAA, Space Environment Center
#
#       Geophysical Alert Message
#
Solar-terrestrial indices for 06 August follow.
Solar flux 70 and mid-latitude A-index 14.
The mid-latitude K-index at 0300 UTC on 07 August was 6 (153 nT).
```

Space weather for the past 24 hours has been minor.  
~~Geomagnetic storms reaching the G1 level occurred.~~

Space weather for the next 24 hours is expected to be minor.  
Geomagnetic storms reaching the G1 level are expected.

Thank you for using the Product Subscription Service. If you would like to remove a product subscription or update the personal information in your account, go to: <https://pss.sec.noaa.gov>. For problems, contact: <mailto:pss.help@noaa.gov>.

Figure IV-4. Geophysical Alert Message

```
:Product: Report of Solar-Geophysical Activity
:Issued: 2007 Aug 22 2200 UTC
# Prepared jointly by the U.S. Dept. of Commerce, NOAA,
# Space Environment Center and the U.S. Air Force.
#
Joint USAF/NOAA Report of Solar and Geophysical Activity
SDF Number 234 Issued at 2200Z on 22 Aug 2007
IA. Analysis of Solar Active Regions and Activity from 21/2100Z
to 22/2100Z: Solar activity was very low.
IB. Solar Activity Forecast: Solar activity is expected to be very
low to low.
IIA. Geophysical Activity Summary 21/2100Z to 22/2100Z:
The geomagnetic field has been quiet.
IIB. Geophysical Activity Forecast: The geomagnetic field is
expected to be quiet 23 - 24 August and quiet to unsettled 25
August.
III. Event Probabilities 23 Aug-25 Aug
Class M 01/01/01
Class X 01/01/01
Proton 01/01/01
PCAF Green
IV. Penticton 10.7 cm Flux
Observed 22 Aug 070
Predicted 23 Aug-25 Aug 070/070/070
90 Day Mean 22 Aug 071
V. Geomagnetic A Indices
Observed Afr/Ap 21 Aug 003/004
Estimated Afr/Ap 22 Aug 004/005
Predicted Afr/Ap 23 Aug-25 Aug 004/005-002/005-010/015
VI. Geomagnetic Activity Probabilities 23 Aug-25 Aug
A. Middle Latitudes
Active 15/15/25
Minor storm 01/01/10
Major-severe storm 01/01/05
B. High Latitudes
Active 20/20/30
Minor storm 01/01/15
Major-severe storm 01/01/10
```

Thank you for using the Product Subscription Service. If you would like to remove a product subscription or update the personal information in your account, go to: <https://pss.sec.noaa.gov>. For problems, contact: <mailto:pss.help@noaa.gov>.

Figure IV-5: Solar Geophysical Activity Report

## Tropospheric Delay Discussion

While tropospheric models are available as internal program components, they do not account for the highly variable local fluctuations in the wet and dry components. The dry, or hydrostatic component comprises 90 percent of the troposphere and can be well modeled (approximately 1 percent error). The wet component as water vapor is the other 10 percent, but cannot be easily modeled (10 percent to 20 percent error). Furthermore, the wet delay component variances are measured in the magnitude of 10's of meters and in seconds and it is extremely difficult to isolate the errors associated with this component in adjustments. Position calculation residuals result from modeling the corrections at the base versus using the “real” conditions at the rover. Also, it should be stated that tropospheric correction models introduce approximately 1mm per meter of height difference between base and rover in delay errors, which is probably not being modeled [Beutler, et al., 1989]. These contribute to a distance-dependent error (along with the ionospheric conditions and ephemerides, which also de-correlate with distance from the base). The tropospheric error mainly contributes to the error in height.

***The single most important guideline to remember about the weather with RT positioning is to never perform RT in obviously different conditions from base to rover.***

This would include storm fronts, precipitation, temperature or atmospheric pressure. Either wait for the conditions to become homogenous or move the base to a position that has similar conditions to the rovers intended location(s).

In RT positioning, there exists a distance correlated error factor, i.e. the further apart the two receivers, the more the inconsistent atmospheric conditions and orbital variations will affect the precision of a computed position. These residual biases arise mainly because the satellite orbit errors and the atmospheric biases are not eliminated by differencing (*see Appendix A*) using the observations from two receivers. Their effect on relative position determination is greater for long baselines than for short baselines (Eckl, et al., 2002). Most GNSS hardware manufacturers specify a 1 part per million (ppm) constant to account for this error (i.e. 1 mm/km). Therefore, this is correlated to the baseline distance. The signals traveling close to the horizon have the longest path through the atmosphere and therefore the errors introduced are hardest to correct, introducing the most noise to the position solution. Unfortunately, by increasing the data mask even higher than 15°, the loss of data becomes a problem for the integrity of the solution and may contribute to higher than desired PDOP.

*It is helpful to partially mitigate the worst effects of atmospheric delay and refraction by setting an elevation mask (cut off angle) of 10°- 15° to block the lower satellites signals which have the longest run through the atmosphere. A 10° mask is recommended.*

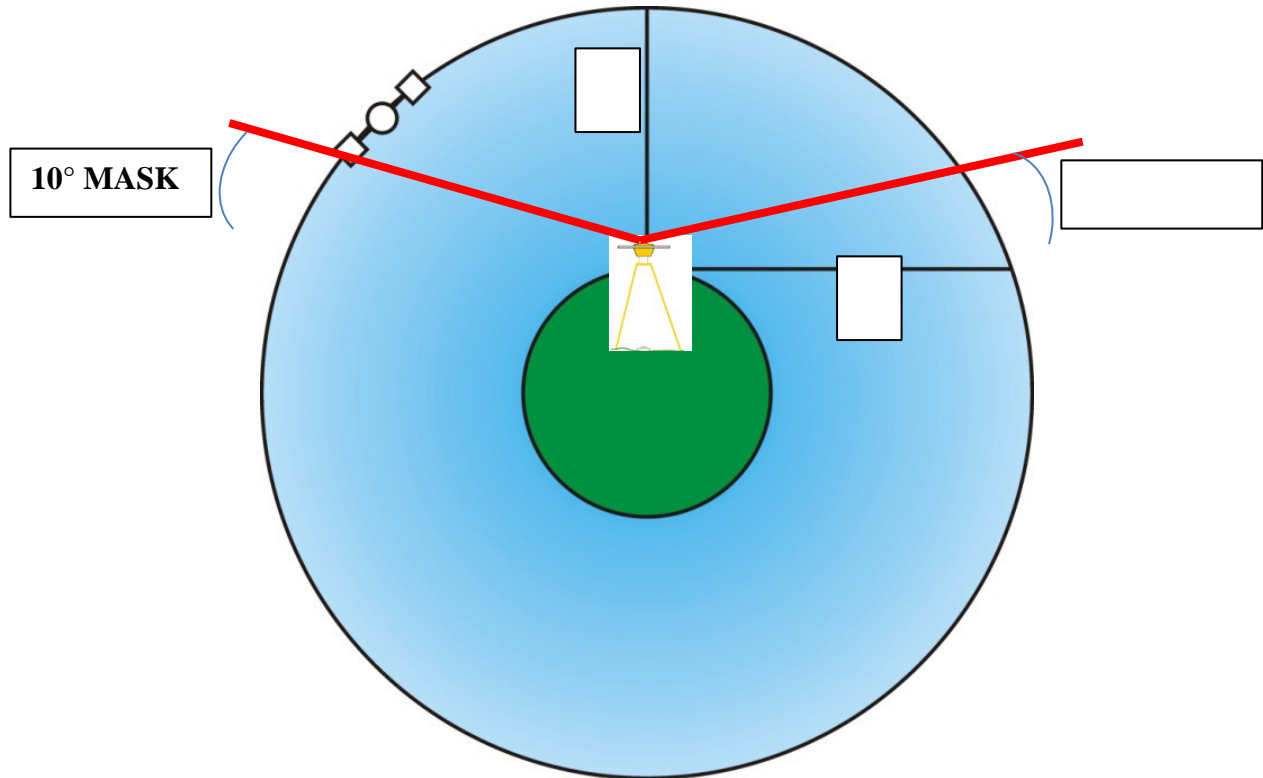

*Figure IV-6: Why the topocentric location of receivers gives rise to GNSS signal paths of differing lengths. Satellite signal path “a” is longer and therefore travels through more atmosphere than “b”, resulting in more signal noise (3-5 times more at low elevations relative to zenith). The 10° mask angle eliminates this noisy data but still retains most of the available signal.*

## **V. Field Procedures**

The control of a classical RT positioning survey is always in the hands of the rover.

Because of the variables involved with RT therefore, this section is the core to achieving accurate positions from RT.

Following are terms that must be understood and/or monitored by RT field technicians:

**Accuracy versus Precision**

**Redundancy**

**Multipath**

**Position Dilution of Precision (PDOP)**

**Root Mean Square (RMS)**

**Site Localizations (a.k.a. Calibrations)**

**Latency**

**Signal to Noise Ratio (S/N or C/N<sub>0</sub>)**

**Float and Fixed Solutions**

**Elevation Mask**

**Geoid Model**

Additionally, the following are concepts that should be understood. Please see the RT positioning glossary (herein) for brief definitions:

**Carrier Phase**

**Code Phase**

**VHF/UHF Radio Communication**

**CDMA/SIM/Cellular TCP/IP Communication**

**Part Per Million (PPM) Error**

**WGS 84, ITRS versus NAD 83**

**GPS and GLONASS Constellations**

Almost all of the above were facets of satellite positioning that “the GPS guru” back in the office worried about with static GPS positioning. Field technicians usually worried about getting to the station on time, setting up the unit, pushing the ON button and filling out a simple log sheet.

Plenty of good batteries and cables were worth checking on also. While the field tech still needs plenty of batteries and cables, she or he now needs to have an awareness of all the

important conditions and variables in order to get good RT results— because in RT positioning, “It Depends” is the answer to most questions.

### **Accuracy Versus Precision**

An important concept to understand when positioning to a specified quality is the difference between “accuracy” and “precision”. The actual data collection or point stake out is displayed in the data collector based on a system precision, which shows the spread of the results (RMS) at a certain confidence level and the calculated 2-D and height (horizontal and vertical) solution relative to the base station in the user’s reference frame. In other words, it is the ability to repeat a measurement internal to the measurement system. Accuracy, on the other hand, is the level of the alignment to what is used as a datum, i.e. to externally defined standards. The “realization” of a datum is its physical, usable manifestation. Therefore, accuracy can be “realized” by published coordinates on passive monumentation, such as is found in the NGS Integrated Data Base (NGS IDB), by locally set monuments, or by assumed monuments. Accuracy can also be from alignment to active monumentation, such as from the NGS Continuously Operating Reference Station (CORS) network or a local RTN. The geospatial professional must make the choice of what is held as “truth” for the data collection. It is expected that the same datum, realized at the same control system monumentation, is held from the design stage through construction for important projects. A professional surveyor, or other qualified geospatial professional, should be involved to assess the datum and its realization for any application. The alignment to the selected truth shows the accuracy of survey. For example, as stated in the NGS 59 document for GPS derived orthometric heights (Zilkoski, et al, 2005), accuracy at the datum level (North American Vertical Datum of 1988 NAVD 88), is less accurate than the local accuracy between network stations. Ties were shown at a 5 cm level to the national datum, while local accuracies can be achieved to the 2 cm level. Subsequent project work done with classical surveying instruments (but still in NAVD 88) could be done at much higher precision, perhaps at the millimeter level, but the accuracy of the tie to the national datum is still 5 cm at best. Because RT positions are being established without the benefit of an internal network adjustment, accuracy at any one point is an elusive concept. It can be seen that if the base station is correctly set up over a monument whose coordinates are fully accepted as truth, correct procedures are used, and environmental conditions are consistent, then the

precision shown would indeed indicate project accuracy. Redundant observations on data points can provide a means to tweak the coordinates in the office software post campaign, but the data are usually not sufficient for a full least squares adjustment.

*Therefore, to get a sense of the accuracy achieved, it is recommended the user's survey be based on proven control monumentation with a high degree of integrity; the data precision is monitored as the work proceeds; points with known values are checked before, during, and after each RT session; and redundant locations are taken on each important point.*

## Redundancy

*Redundancy is the single-most important RT procedure for confidence in positioning results.*

When conducting research for the GPS orthometric height guidelines in the late 1990s, NGS showed that the closest alignment to truth was obtained by the simple average of two or more observations of the point of interest. Staggering the observations by four hours on the same day or different days in the same 30 day time span (as the GPS constellation repeats 4 minutes earlier each day), will have the base/rover use a different set of satellites from the GNSS constellation and produce a different geometric signal figure. Thus, this will have the benefit of using different multipath conditions for the different observations and will often produce a different solution - allowing for a more precise overall picture of expected results for all future observations. A recent RTN study in Great Britain by the University of Newcastle on Tyne, (Edwards, et al., 2008) has shown redundant observations staggered by more than 45 minutes add little benefit to the network solution. This study was conducted in the spring of the year 2008 in the 54° latitude range using the RTN error interpolations at points open to the sky (and thus with little multipath). Additionally, 5% of the RT observations were removed as outliers, and the RMS of the results were higher than put forth for the 95% confidence level in this Chapter for the RT 1 precision criteria. For these reasons, it is felt that the Newcastle study, while invaluable for RTN positioning, would be like comparing apples to oranges for the single base conditions addressed in these guidelines. Therefore, at the present time, NGS is still recommending using different satellite geometry for the redundant observations on important points - mainly because of the variation in multipath conditions that will be faced by the rover. Furthermore, the varying seasonal influences such as fluid withdrawal, temperature extremes, variation in the wet component of the troposphere,

ionospheric scintillation, as well as modeling in relatively large areas of relief would be better served with the more conservative approach.

## Multipath

Multipath error cannot be easily detected in the rover or modeled in the RT processing. Basically, anything which can reflect a satellite signal can cause multipath and introduce error into a coordinate calculation. When a reflected signal reaches the receiver's antenna, the transit time is interpreted as if the signal took a direct path from the satellite, even though in reality it took a longer time by being reflected. This would "trick" the receiver into using the longer time (or therefore, longer distance) in its solution matrix to resolve the ambiguities for that satellite. This bias in time/distance introduces noise to the solution (much like a "ghost" on a television with a bad "rabbit ears" antenna) and can cause incorrect ambiguity fixes or noisy data (as may be evidenced by higher than expected RMS). Just a one nanosecond delay in the time means about 30 cm in range error. Multipath is cyclical (over 20 minutes to 25 minutes typically) and static occupations can use sophisticated software to model it correctly in post-processed mode. The rapid point positioning techniques of RT prevent this modeling. Trees, buildings, tall vehicles nearby, water, metal power poles, etc. can be sources of multipath. GNSS RT users should always be aware of these conditions.

***Areas with probable multipath conditions should not be used for RT positioned control sites—especially not for a base station position. These sites include locations under or very near tree canopy, structures within 30 m that are over the height of the antenna, nearby vehicles, nearby metal objects, abutting large water bodies, and nearby signs.***

Although newer GNSS equipment can mitigate multipath much better than older equipment, there is not enough time to model the multipath present at any point because the typical RT occupation will only be anywhere from a few seconds to a few minutes. Indeed, the firmware in the rover receiver and data collector will not address this condition and will continue to display the false precision as if multipath was not present. Besides contributing to the noise in the baseline solution, multipath can cause an incorrect integer ambiguity resolution and thus give gross errors in position, particularly the vertical component. It has been seen to give height errors in excess of 2 dm because of incorrect ambiguity fixes and noise. Multipath isn't always apparent and it's up to the common sense of the RT user to prevent or reduce its effects. It is recommended to get redundant observations with different satellite geometry (three-hour

staggered times) to help mitigate multipath error.



*Multipath Conditions can cause unacceptable errors by introducing noise and incorrect ambiguity resolution because of signal delay.*

## Position Dilution of Precision

*PDOP* is a unitless value reflecting the geometrical configuration of the satellites in regard to horizontal and vertical uncertainties. Stated in a simplified way, DOP is the ratio of the positioning accuracy to the measurement accuracy. Error components of the observables are multiplied by the DOP value to get an error value compounded by the weakness in the geometrical position of the satellites, as can be shown relative to the intersection of their signals. This is depicted in *Diagrams II-2 and 3*. Therefore, lower DOP values should indicate better precision, but cannot be zero, as this would indicate a user would get a perfect position solution regardless of the measurement errors. Under optimal geometry with a large numbers of satellites available (generally 13 or more), PDOP can actually show (usually very briefly) as a value less than one, indicating the RMS average of the position error is smaller than the measurement standard deviation. PDOP is related to horizontal and vertical DOP by:

$$PDOP^2 = HDOP^2 + VDOP^2.$$

Another DOP value, Relative Dilution of Precision (RDOP), has been researched as a better indicator for the effects of satellite geometry for differential carrier phase positioning (Yang, et al, 2000). However, because most data collectors display PDOP during field positioning, it remains the value these guidelines must address. See the different **Accuracy Classes** in this section for suggested PDOP values.

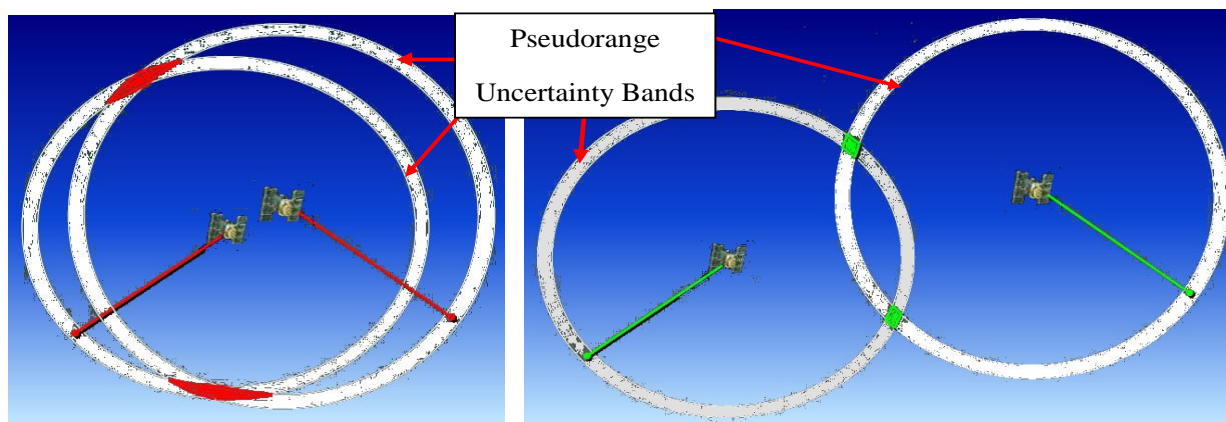

Diagram V-1

**High PDOP: Satellites Close Together**

Diagram V-2

**Low PDOP: Satellites Spread**

Note the difference in area of the intersections. In a three-dimensional sense with multiple satellites, it would be reflected in the difference of hyperbolic intersections displayed in polyhedron volumes. Mathematically, the lowest possible volume polyhedron formed by the signal intersections would have the lowest PDOP.

## Root Mean Square

RMS is the statistical measure of precision (not accuracy) that can typically be viewed in the data collector. RMS indicates the numeric quality of the solution related to the noise of the satellite ranging observables; it is independent of satellite geometry. Many data collectors display this as a  $1\sigma$  (one sigma or 68 percent confidence) level. The user should double these horizontal and vertical values to see the approximate precision at the desirable 95 percent confidence level.

***When viewing the RMS on the data collector screen, the user should be aware of the confidence level. Some displays show a 68% confidence for the horizontal and vertical precision.***

## Constraining to Passive Monuments

Horizontal and ellipsoid height positions are readily and accurately obtained from active stations, such as those in the national CORS system which serves as the realization of our NAD 83 datum. However, the orthometric height component of a single baseline RT position is usually based on passive monumentation, whereas high vertical accuracy order bench mark monuments are the realization of the NAVD 88 datum. Using single base RT procedures, the user typically promulgates the base station horizontal position and orthometric height to the collected data on points of interest in her or his work. Regardless of the base station's accuracy level in its

alignment to the horizontal and vertical datums, the rover's position can never by RT practice be more accurate than that of the base (the rover is solely aligned to the base in this case and thus has no other connection to the datum. Also, recall: the ppm error associated with single base RT, the error in an applied hybrid geoid model, the variation in the obtained coordinates by atmospheric conditions and other satellite related factors, and possible multipath noise). Several issues arise from this methodology in regard to the actual "ground truth" of the obtained positions:

**Case 1: One passive monument as truth.** It can be seen that, if the base station occupies a stable, trusted monument of verified accuracy, whose position and orthometric height are known to be in a certain datum or projection, and/or with a certain orthometric height or elevation, then the RT points obtained in a local project sense will reflect a certain precision in relation to the base and an accuracy correlated to the base's alignment to the referenced datums (see Accuracy and Precision, in this chapter). When using this base as the "truth," the user enters the horizontal and vertical coordinates of the point into the data collector. These coordinates may be references to the monument's physical location on the ground using a project "height" (usually causing a one point tangent ground projection), or they may be referenced to a transformation defined in the data collector firmware, causing data points to be essentially taken on that projection surface (and therefore not ground based). For example, if the base monument coordinates are entered as being referenced to a grid coordinate projection, such as SPC whose transformation from the WGS 84 (GPS) datum is built into the collector's firmware, the points of interest are located by the rover as grid coordinates, and inversed distances will not reflect ground distances. It is possible to automatically apply a combined factor to these generated points to reflect the project scale and ellipsoid height factors at the project site. However, the user must be aware this will create "ground" coordinates that look similar to the grid coordinates, but differ from the grid values at the same point. Many GNSS practitioners select one published orthometric height (or other local height) on one monument to act as project truth, and thus shift all heights based on this "vertical reference datum," whether thought to be aligned with a particular datum or not. Since only one passive monument is constrained, it is critical check shots be taken before collecting new data. It should be remembered that a hybrid geoid model can still be applied to the point data collected.

**Case 2: Unknown base station coordinates.** RT locations can proceed from a local tangent projection established from an autonomous point. Usually, the vectors are shifted post campaign

to the correct position coordinates of the base station entered. It is also possible to do a “GPS resection,” where other trusted monuments surrounding the project are visited by the rover. The GNSS locations are used in the collector to establish a refined coordinate on the previously autonomous value of the base station. This is essentially part of a routine known as a “calibration” or “localization” to many users, as in Case 3, and establishes a planar projection surface that is best fit to the coordinates entered.

**Case 3: Constraining multiple passive monuments around a project.** Many users practice in areas where passive monumentation has been used over many years and in many projects. Indeed, local regulations or requirements may even dictate these passive monuments be used for all work. In areas where the user wishes to constrain his or her work to these legacy passive monuments, or even to non-geodetic values, site localizations can be performed. These passive monuments may or may not be precisely aligned to a particular datum, but would be proper to use for the sake of project accuracy, continuity and construction compatibility. Using the GNSS manufacturer’s firmware in the field, or software in the office, it is a relatively easy task to perform a least squares best fit to these monuments. The user’s software/firmware performs a rotation, translation and scale transformation from the WGS 84 datum realized in the broadcast satellite ephemeris, to a local projection as realized on physical monuments visited in the field survey (the GNSS manufacturer’s software performs an intermediate step to a project oriented projection—Transverse Mercator for example). The coordinates entered for these monuments establish a best fit planar projection, either horizontal, vertical, or both—depending on what is entered and constrained. Residuals are reviewed for outliers. The user should be extremely careful in what is considered an outlier in this adjustment. It is possible that one monument is “correct” to the user’s reference frame and all the others in the adjustment are the outliers. The user must know the quality of the passive monuments.

Because of its built-in capabilities, most RT users utilize this method. However, like much of the high precision work produced, the results must be reviewed by a competent geospatial professional.

***RT localizations allow the user to transform the coordinates of the control monumentation positioned with their RT-derived positions in the WGS 84 datum, to the user datum (even if it’s assumed), as realized by the user’s coordinates on the monuments.***

Before performing a localization, the project site should be evaluated, and after control research and retrieval, the monumentation coordinates to be used for the localization should be

uploaded to the field data collector.

***To have confidence in a site localization, the project site must be surrounded by at least four trusted vertical control monuments and four trusted horizontal control monuments which, to the greatest extent possible, form a rectangle.***

The monuments can be both horizontal and vertical control stations, but should be of sufficient accuracy to be internally consistent to the other localization control at a level greater than the required RT project accuracy. Adding more trusted control meeting these criteria will add to confidence in the localization, especially if they can be spaced throughout the project area. For the limiting accuracy of RT field work, many GNSS software and hardware manufacturers state their RT positioning accuracies as 1 cm + 1 ppm horizontal and 2 cm + 1 ppm vertical (at the 68 percent or one sigma level). This is further substantiated by published ISO testing standards in ISO/PRF 17123-8 (ISO, 2008). Thus, for a localization control spacing of 20 km, the localization adjustment statistics might be recommended to show less than a 2 cm horizontal residual and less than a 4 cm vertical residual at a 95 percent confidence (twice the confidence of the RT work done with 68 percent confidence). Site localizations can be performed in the field by a competent RT user and imported into the office GNSS software, or performed in the office and uploaded to the data collector. The firmware/software will yield horizontal and vertical residuals which must be reviewed to check for outliers. It can be seen that this is a good way to assess the relative accuracy of all the existing project control. It must be remembered, however, that any localization performed to the passive marks takes coordinates—whether ground based or not—and fits them to the physical marks (and thus imparts a scale factor).

***It is critical that all project work is done using the same correct and verified localization. Different localizations can result in substantially different position coordinates.***

#### **Case 4: Performing a quick geodetic transformation to a local project projection**

It is possible to do a relatively quick transformation computation from an established datum, such as NAD 83, to a ground-based local project map projection in the office prior to the field campaign, or even in the data collector while in the field. Many larger map projection areas that might be county-wide or regional, but still ground based, can also be established with a little more computational work. The goal is to minimize linear distortion at the topographic surface, which requires use of projections with a unique scale factor at every point (i.e., conformal projections). The advantages of using this method are several (Dennis, 2008):

1. The definition is cleaner in that it has no appearance of state plane coordinate values, (typically) has smaller coordinate values, and does not create another datum

as would be the case of scaling the ellipsoid to ground.

2. It is more readily compatible with GIS and other mapping, surveying, and engineering software.
3. It generally covers larger areas with less distortion than a state plane projection taken to ground.
4. It can be designed in a manner that minimizes convergence angles (and hence arc-to-chord corrections), which is unchanged by a modified state plane transformation.

Either a Transverse Mercator (TM) projection, or one parallel Lambert Conformal Conic (LCC) projection, will work adequately for areas under less than about 35 miles wide (about 1000 square miles, if more-or-less equi-dimensional). For larger areas, Earth curvature begins to have a noticeable impact on the distortion, at which point the type of projection used becomes more important. Other common conformal projections that can be used are the Oblique Mercator and the Oblique Stereographic. For small areas, it is recommended to use a Transverse Mercator projection, unless inadequate for the site, since it is the projection most widely supported in software (although this limitation is decreasing as more vendors add more projections to their software).

This method requires proper metadata to maintain the geodetic trail back to the datum. These data include: The geometric reference system (i.e., datum), datum realization tag, datum epoch (time) reference, linear unit, and the projection definition. This latter item consists of the latitude and longitude of grid origin, false northings and eastings at the grid origin, and the scale factor applied to the central meridian (for TM), standard central parallel (for LCC), or skew axis (for OM) along with skew axis azimuth.

A local low distortion projection is defined directly from the datum based on the local topography and is exclusive of the passive realization of that datum. Obviously, the passive marks used for control within the project area should be validated once the projection is defined (which is true regardless of the coordinate system used). It is possible to refine the scale factor to better fit the passive control if necessary, or to refine it based on a detailed analysis of distortion at the topographic surface. The steps necessary to create a local projection are summarized below:

1. Define the project area and choose a representative ellipsoid height ( $h_0$ ).

2. Place the projection axis (central meridian for TM, standard parallel for LCC) near the center of the project.
3. Compute the scale at the project axis using  $h_o$ . Use the formula:  
 $k_o = 1 + (h_o \div R_E)$ , where  $k_o$  = scale at projection axis,  $R_E$  = radius of Earth (ellipsoid) at the project latitude (a geometric mean radius of curvature of 6,373,000 m or 20,910,000 ft works reasonably well for the coterminous United States). Round  $k_o$  to five or six decimal places (use at most seven for small areas).
4. Define false northing and easting for an origin so that all project coordinates are positive. Make the coordinates at the central meridian and a parallel of origin (south of project) using the smallest integer values that give positive coordinates everywhere in the area of interest. Also define the latitude and longitude of grid origin (including central meridian and standard parallel, as applicable) to no more than the nearest arc-minute. The purpose of this step (and rounding  $k_o$  to six decimal places) is to provide a clean coordinate system definition.

Check passive control (or points of known topographic height) at the project extremes for distortion (both in extremes of area and height). If the computed distortion based on these ellipsoid height check points is too high, the projection axis scale factor can be adjusted to reduce distortion.

## Latency

Latency is the delay of the received satellite signal data and correction information at the base to be wirelessly broadcast, received by the rover radio, transferred to the rover receiver, correction-computed and applied for the current common epoch, sent to the data collector and displayed for the user. The position the user views on the data collector screen can be up to 5 seconds old, but typically an effective latency of 2 or 3 seconds is the maximum experienced. The data can be updated (or sampled) at a much higher rate, say 5 Hz, but the usable coordinate is usually produced at .33 to 1 Hz.

***It is recommended to use data with latencies no greater than 2 seconds.***

## Signal to Noise Ratio

Receivers must process GNSS signals through background noise. This can be from atmospheric conditions, radio frequency interference or from hardware circuitry. Since GNSS signals are relatively weak (the total transmitted power from a satellite is less than 45 w!), it is

important to use data that doesn't fall below acceptable noise levels (a common level is given as 30 dB). Signal-to-noise ratio (SNR) can be an indicator of multipath, if other contributing noise factors, such as antenna gain, can be removed. The signal-to-noise ratio is the ratio of the average GNSS signal power to the average level of background noise, often given in decibels (dB). The higher the ratio, the less obtrusive the background noise. The signal to noise ratio is denoted by the abbreviation S/N or SNR (or sometimes carrier signal amplitude over 1 Hz =  $C/N_0$ ). It is usually based on a decibel base 10 logarithmic scale. Most GNSS firmware in the data collectors are capable of displaying this value on some kind of scale. Unfortunately, unlike GPS code and phase observables, a standard practice for computing and reporting SNR has not been established. Thus, the value and the units used for reporting SNR differ among manufacturers. At this time, it is not possible to give independent numerical values to the SNR for all receiver brands. Therefore, the only recommendation made is to refer to each manufacturer's reference material and support system to try to ascertain a minimum SNR (or  $C/N_0$ ). Some considerations to ponder include:

- NMEA message type GSV supposedly shows  $C/N_0$  in dB.
- Current Rinex 2.10+ versions allow the SNR to be reported in the original observations.
- Comparison of SNR between satellites can show the source of the cleanest data.

*(See Langley, 1997)*

## **Float and Fixed Ambiguities**

In the quest to resolve the ambiguous number of whole carrier cycles between each satellite and each GNSS receiver's antenna added to the partial cycle which the receivers' record after locking on to the satellites, many iterations of least squares adjustments are performed. A first list of candidates produces a set of partial whole cycle counts, that is, a decimal number to each satellite for each frequency. This decimal cycle count is said to be the "float" solution, one that still has not yet forced the number of whole cycles to take an integer value. Usually, while stationary, the positional RMS and horizontal and vertical precisions will slowly decrease as the rover receiver iterates solutions. The user will see these indicators go from several meters down to sub-meter. Sometimes the solution rapidly goes to fixed and these iterations are not seen.

***The user must be aware of the solution state and should wait until the solution is displayed as fixed before taking RT observations.***

As soon as the solution is “fixed” and the best initial whole number of cycles has been solved, the data collector will display survey grade position precision at the sub-centimeter level.

### **Elevation Mask**

Because GNSS satellite signals have the longest paths through the atmosphere at low elevations from the horizon, it is advantageous to set a cut-off angle to eliminate the noisy data. The base station and rover are typically set to an elevation mask of between  $10^\circ$  and  $15^\circ$ . In addition to this mask, individual satellites can be switched to inactive in the firmware. This may be of some advantage where there are many satellites available, but due to obstructions, a specific satellite may be at a higher noise level and become a detriment to a robust solution. Typically, the satellites’ elevations and azimuths can be viewed graphically in a data collector screen. It is recommended to set the elevation mask to at least  $10^\circ$  to eliminate the noisiest data (but not more than  $15^\circ$  so as not to eliminate usable data).

### **The NGS Hybrid Geoid Model**

NGS has, for a number of years, provided a hybrid geoid model from which users of GPS could take the field-produced NAD 83 ellipsoid heights and compute NAVD 88 orthometric heights in the continental United States, being also introduced in Alaska in 2007. The hybrid geoid model gives a distance or separation between the two surfaces defined as NAD 83 and NAVD 88. Although this model has been consistently updated, densified and improved, it is expected the resolution of the model would lead to interpolation errors or residuals. As of this writing, users can expect relative elevation accuracy of 4.8 cm (2 sigma) internal accuracy, which includes GPS observation error. Error in the geoid is expected at about 2 cm (2 sigma) at about 10 km wavelength. Nothing can really be said about absolute accuracy because of the very irregular data spacing (some regions are very sparse while others are saturated). Hence, while the apparent local accuracy might look good, that may be due to the fact that only a few points were available and were easily fit. That being said, many parts of the United States are extremely well served by applying the hybrid geoid model. Height Modernization practices can produce 2 cm local orthometric height accuracy from static GPS procedures. It is incumbent upon the GNSS RT user to know the resolution, accuracy and gradient slope of the local geoid model for his or her project area. In the user’s data collector, manufacturer’s RT algorithms can apply the hybrid

geoid model with or without an inclined plane produced from a localization.

***For best vertical results, it is recommended to apply the current hybrid geoid model in addition to any localization to the vertical control.***

## Communication Links

It is important to reiterate that user expertise and knowledge enables accurate data collection, where inexperience may yield less than satisfactory results. A prime example is communication integrity. When radio or cellular communication becomes intermittent or erratic, but does not fail, positional data can degrade in accuracy. The exact reasons for the lowering of accuracy appear unclear due to proprietary firmware algorithms, but perhaps are related to the variation in the latency of data reception. Regardless, this condition should be handled with caution if the point accuracy is of any importance. Also, there are areas where cell voice coverage is strong, but data communication is intermittent (and vice versa). Furthermore, if the rover firmware takes an extended time (much longer than a normal fix time) to resolve the ambiguities and display a fixed position, there could be an incorrect cycle count resolution and the accuracy would be insufficient for surveying or engineering applications. As with multipath, there is no specific indication in the data collector that there is a bad fix, except perhaps an increase in RMS error. The good news is that the receiver is constantly doing QA/QC on the ambiguity resolution strength. Indeed, it is stated in various GNSS equipment manufacturers' literature that newer receivers use better RTK algorithms, and as a result produce better accuracy over longer baselines and lower elevation masks, with a higher signal to noise ratio, and more robust ambiguity resolution. (See Appendix A for a case study of positioning over various baseline lengths in Vermont by NGS State Geodetic Advisor, Dan Martin, using newer GNSS units). As a good practice, therefore:

***To collect important positional data, the communication link should be continuous. The GNSS solution should become fixed in a “normal” amount of time and should remain fixed for the duration of the data collection at the point.***

A “normal” time period is one seen by the user to produce a reliable ambiguity resolution from a local base station in past data collection campaigns using proper conditions and procedures.

## Checks on Known Points

Single-Base RT field work requires a confidence that each base setup is done correctly; otherwise, the errors will be biases in every data point created from the setup.

***Before beginning new point data collection, a check shot should ALWAYS be taken on a known point.***

This should provide a method of detecting setup blunders, such as incorrect antenna heights or base coordinates. It also provides a check on the initialization or ambiguity resolution. Periodic checks on known points should also be done as work progresses. Finally, a check should be done before the end of the setup. The user should decide which points in their project area are suitable for checks. For work in the higher accuracy classes, it is recommended to check known and trusted high stability monuments, such as those of high integrity found in the NGS data base. If none are available near a particular project, perhaps a point previously located from such a monument could be used as verification that the RT setup is of the desired accuracy. It is possible to travel with a vehicle and keep the rover initialized. Magnetic antenna mounts are available to keep the antenna accessible to the sky, and thus to the satellites. It should be noted, however, that passing under a bridge or overpass or traversing a tunnel will obviously cause loss of lock at the rover, requiring a re-initialization. Generally,

***To collect important positional data, known and trusted points should be checked with the same initialization as subsequent points to be collected.***

An “important point” may be, for example, any point established by RT to be used as a control station for further data collection or a photo control reference point. “Known and trusted” points are the existing high accuracy points in the project envelope.

## Accuracy Classes

The term “accuracy,” in this case, actually refers to the precision from a base station, correctly set over a monument held as truth. The accuracy of the rover positions will be less than the accuracy of the base station’s alignment to the user’s datum.

**It is important to know what accuracy is needed before performing the RT field work.**

Besides the previously stated guideline for continuous communication and fixed ambiguities for these guidelines, the equipment must be in good working condition. This means: no loose tripod legs, the actual fixed height has been checked (worn fixed height pole feet, unseated pole

feet and variability in the height settings in those fixed height poles using dowels to hold a particular height can yield biases of millimeters to even a centimeter in base heights), strong batteries are used, the units perform to manufacturers specs (ISO, 2008), and the level bubbles have been adjusted (see Appendix C). Further assumptions are: there are no blunders in data collection or entered pole heights, the rover and base are GPS dual frequency, with or without GLONASS, and are receiving observables with a cut-off angle (elevation mask) of  $10^{\circ}$  to  $15^{\circ}$ , the base has been positioned in as open a site as possible, with no multipath or electrical interference, and it occupies an adjusted control point within the site localization (if any), and its coordinates have been correctly entered as the base position.

### **Accuracy Classes Rationale**

Listed below are data collection parameters to achieve various accuracies with a strong amount of confidence (95 percent level). These have been developed from years of best practices from the experiences of many RT users and also reflected in some existing guidelines (e.g. Caltrans, 2006). The rationale for publishing these guidelines without extensive controlled scientific testing is correlated to their use life and the needs of the user community. To run controlled experimentation with the plethora of variables associated with single base RT positioning would take an inordinate amount of time and effort and would likely produce results that would be outdated by the time of their release. To meet the needs of the large RT user community in a timely manner, the decision was made to employ best practices that could be adjusted to meet actual valid field location results, as needed. Additionally, the changing GNSS constellations and other new or improving technologies require a dynamic stance with these guidelines. New signals, frequencies and satellite constellations will undoubtedly change the recommended procedures and accuracy classes that follow. Finally, the rapid growth of RTN stresses the need to port these single base guidelines to those for users of the networked solutions, rather than spend extensive time in research for single base applications.

**Note:** Empirically, it has recently become evident that using newer GNSS hardware, firmware and algorithms may produce the various following accuracies over much longer baseline distances. Additionally, redundant positions at staggered times are showing a much closer numerical comparison than previously seen. This may mean the Class RT1 accuracies could be obtained using the criteria for Class RT2, etc. Regardless of this, the user should at least be able to achieve the desired accuracy by using the appropriate criteria herein.

**Class RT1** Precisions: typically 0.01 m – 0.02 m horizontal, 0.02 m – 0.04 m vertical (two sigma or 95 percent confidence), two or more redundant locations with a staggered time interval of 4 hours from different bases adjusted in the project control, each RT location differing from the average no more than the accuracy requirement. Discard outliers and re-observe if necessary. Base stations should use fixed height tripods and be on opposite sides of the project, if possible. Baselines  $\leq 10$  KM (6 miles). Data collected at a 1-second interval for 3 minutes (180 epochs), PDOP  $\leq 2.0$ ,  $\geq 7$  satellites, position solution RMS  $\leq 0.01$  m. No multipath conditions observed. Rover range pole must be firmly set and leveled with a shaded bubble before taking data. Use fixed height Rover pole with bipod or tripod for stability.

**Class RT2** Precisions: typically 0.02 m – 0.04 m horizontal, 0.03 m – 0.05 m vertical (two sigma or 95 percent confidence), two or more redundant locations staggered at a 4-hour interval, two different bases recommended, bases within the project envelope, each location differing from the average no more than the accuracy requirement. Discard outliers and re-observe if necessary. Base stations should use fixed height tripods. Baselines  $\leq 15$  KM (9 miles). Data collected at a 5-second interval for one minute (12 epochs). PDOP  $\leq 3.0$ ,  $\geq 6$  satellites, position solution RMS  $\leq 0.015$  m. No multipath conditions observed. Rover range pole must be level before taking data. Use fixed height rover pole with bipod or tripod for stability.

**Class RT3** Precisions: typically 0.04 m – 0.06 m horizontal, 0.04 m – 0.08 m vertical (two sigma or 95 percent confidence). Redundant locations not necessary for typical locations; important vertical features such as pipe inverts, structure inverts, bridge abutments, etc. should have elevations obtained from leveling or total station locations, but RT horizontal locations are acceptable. Baselines  $\leq 20$  KM (12 miles). Data collected at a 1-second interval for 15 seconds (15 epochs) with a steady pole (enter attribute information before recording data). PDOP  $\leq 4.0$ ,  $\geq 5$  satellites, position solution RMS  $\leq 0.03$  m. Minimal multipath conditions. Okay to use Rover pole without bipod; try to keep pole steady and level during the location.

**Class RT4** Precisions: typically 0.1 m – 0.2 m horizontal, 0.1 m – 0.3 m vertical (two sigma or 95 percent confidence). Redundant locations not necessary for typical locations. Any baseline

length okay, as long as the solution is fixed. Data collected at a 1-second interval for 10 seconds (10 epochs) with a steady pole, but okay to enter attributes as data is collected. PDOP  $\leq 6.0$ ,  $\geq 5$  satellites, position solution RMS  $\leq 0.05$  m. Any environmental conditions for data collection are acceptable, with the previous conditions met. Rover pole without bipod okay.

With a base station considered as coordinate “truth,” the precisions of the observations taken at the rover reflect the accuracy to this truth. That is, the precision is the measure of local accuracy. If constraints have been applied to local passive monuments, it is important the base station be related to the localization performed. Therefore:

**For Accuracy Classes RT1 and RT2:**

*If a localization has been performed, the base station must be inside the localization envelope and must be connected to the nearest localization control monument by a maximum of 1 cm + 1 ppm horizontal and 2 cm + 1 ppm vertical tolerances at the 95 percent confidence level.*

**For Accuracy Classes RT3 and RT4:**

*If a localization has been performed, the base station must be inside the localization envelope and should be connected to the nearest localization control monument at the accuracy level of the survey.*

For Accuracy Classes requiring redundant locations, in addition to obtaining a redundant location at a staggered time, use this procedure for each location *to prevent blunders*:

1. Move at least 30 m from the location to create different multipath conditions, invert the rover pole antenna for 5 seconds, or temporarily disable all satellites in the data collector to force a re-initialization, then relocate the point after reverting to the proper settings.
2. Manually check the two locations to verify the coordinates are within the accuracy desired or inverse between the locations in the data collector to view the closure between locations. (This operation can be automated in some data collectors). Each location should differ from the average by no more than the required project accuracy.
3. Optionally, after losing initialization, use an “initialization on a known point” technique in the data collector. If there was a gross error in the obtained location, initialization will not occur.

4. For vertical checks, change the antenna height by a decimeter or two and relocate the point. (*Don't forget to change the rover's pole height in the data collector!*)

ACCURACY CLASS SUMMARY TABLE

	CLASS RT1	CLASS RT2	CLASS RT3	CLASS RT4
<b>ACCURACY (TO BASE)</b>	0.015 HORIZONTAL, 0.025 VERTICAL	0.025 HORIZONTAL, 0.04 VERTICAL	0.05 HORIZONTAL, 0.06 VERTICAL	0.15 HORIZONTAL, 0.25 VERTICAL
<b>REDUNDANCY</b>	≥ 2 LOCATIONS, 4-HOUR DIFFERENTIAL	≥ 2 LOCATIONS, 4-HOUR DIFFERENTIAL	NONE	NONE
<b>BASE STATIONS</b>	≥ 2, IN CALIBRATION PROJECT CONTROL	RECOMMEND 2 IN CALIBRATION	≥ 1, IN CALIBRATION	≥ 1, IN CALIBRATION RECOMMENDED
<b>PDOP</b>	≤ 2.0	≤ 3.0	≤ 4.0	≤ 6.0
<b>RMS</b>	≤ 0.01 M	≤ 0.015 M	≤ 0.03 M	≤ 0.05 M
<b>COLLECTION INTERVAL</b>	1 SECOND FOR 3-MINUTES	5 SECONDS FOR 1-MINUTE	1 SECOND FOR 15 SECONDS	1 SECOND FOR 10 SECONDS
<b>SATELLITES</b>	≥ 7	≥ 6	≥ 5	≥ 5
<b>BASELINE DISTANCE</b>	≤ 10 KM	≤ 15 KM	≤ 20 KM	ANY WITH FIXED SOLUTION
<b>TYPICAL APPLICATIONS</b>	PROJECT CONTROL CONSTRUCTION CONTROL POINTS CHECK ON TRAVERSE, LEVELS SCIENTIFIC STUDIES PAVING STAKE OUT	DENSIFICATION CONTROL TOPOGRAPHIC CONTROL PHOTOPOINTS UTILITY STAKE OUT	TOPOGRAPHY CROSS SECTIONS AGRICULTURE ROAD GRADING SITE GRADING	SITE GRADING WETLANDS GIS POPULATION MAPPING ENVIRONMENTAL

### Quick Field Summary:

- Set the base at a wide open site.
- Set rover elevation mask between 10° & 15°.
- The more satellites, the better.
- The lower the PDOP, the better.
- The more redundancy, the better.
- Beware multipath.
- Beware long initialization times.
- Beware antenna height blunders.
- Survey with “fixed” solutions only.
- **Always** check known points before, during and after new location sessions.
- Keep equipment adjusted for highest accuracy.
- Communication should be continuous while locating a point.
- Precision displayed in the data collector may be at the 68 percent confidence level (or 1σ), which is only about half the error spread to get 95 percent confidence.

- Have back up batteries & cables.
- RT does not like tree canopy or tall buildings.

## VI. Further Work in the Office

RT baselines can be viewed and analyzed in most major GNSS software. The data are imported into the software with the field parameters and project configuration intact. At this point, a re-localization can be done, or the field localization (if any) can be reviewed and left unaltered.

*If the site localization is changed in the office, resulting in new coordinates on all located points, the new localization information must be uploaded to the data collector before any further field work is done for that project.*

Communication between field and office is critical to coordinate integrity and consistency of the project.

*If the data are collected with covariance matrices and there is redundancy or connecting points, a post campaign adjustment can also be performed (although with typically less accuracy than with static network observations).*

The RT survey baselines can be checked by the use of generated reports or viewing each baseline graphically. (See Diagram VI-1.)

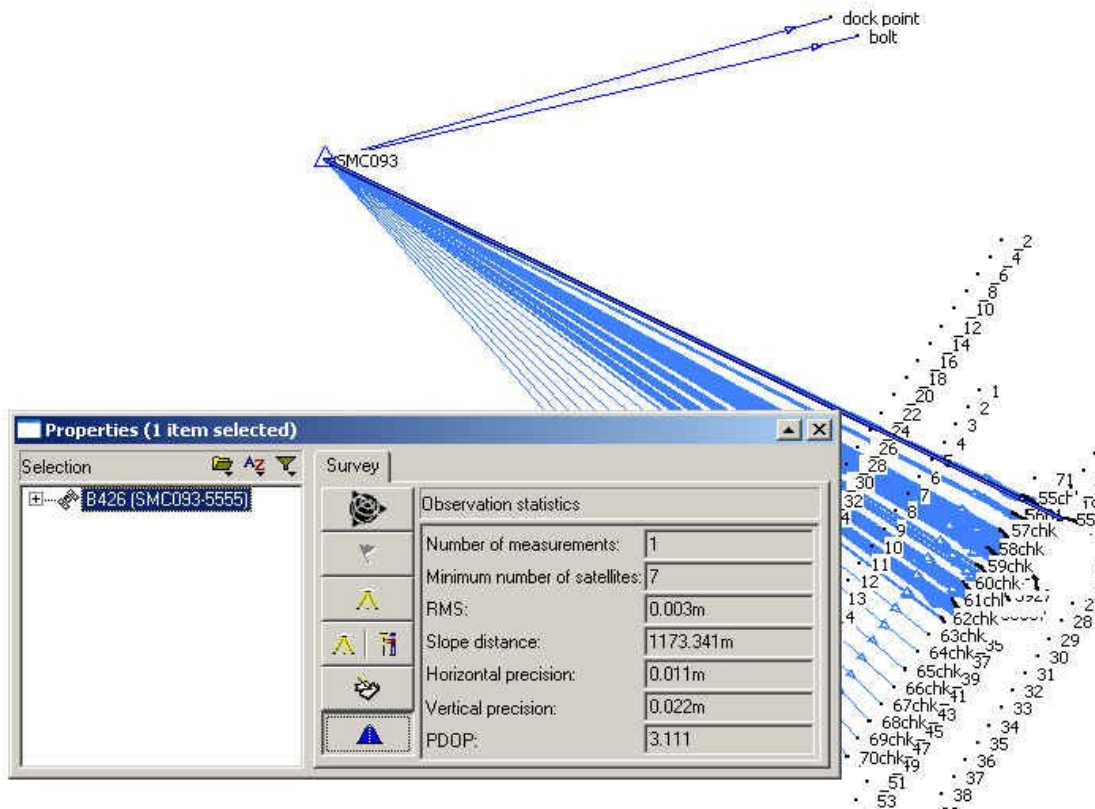

Diagram VI-1. Viewing baseline properties in the GNSS software

**Entering in the correct coordinates of field checked stations will let the user actually adjust all the RT located points holding those known values.**

Additional properties to office check in the RT data include:

- Antenna heights (height blunders are unacceptable and can even produce horizontal error) (Meyer, et.al, 2005).
- Antenna types
- RMS values
- Redundant observations
- Horizontal & vertical precision
- PDOP
- Base station coordinates
- Number of satellites
- Localization (if any) residuals (if calibrating horizontally, also check scale of calibration, and if using a multi-point vertical calibration, also check slope of correction surface).

## A Word on Metadata

RT positioning yields coordinates from the field work performed, but little else in the way of information on the equipment used and how the work was performed. The responsible geospatial professional must put procedures in place to ensure adequate metadata (data about data) is recorded. It is recommended a *standardized form* be produced to accomplish a uniform and complete archival of pertinent information. Such data should include:

- What is the source of the data?
- What is the datum/adjustment/epoch of the base station(s)?
- What were the field conditions? Temperature, wind, precipitation, storms?
- What equipment was used, especially, what antenna?
- What firmware was in the receiver & collector?
- What redundancy, if any, was used?
- Were local passive monuments constrained (a localization was performed)? Horizontal? Vertical/both? How did the known points check? Be sure to record the date of the localization (if any) and where it was performed (field or office).
- Date, time and field technicians' names.

## VII. Contrast to RTN Positioning

It is important that users are aware of the different methodologies available to them for their work. With the convergence of maturing technologies, such as wireless Internet communication, later generation GNSS hardware and firmware, and augmented satellite constellations, RT positioning is becoming a preferred method of data acquisition, recovery and stakeout to many users in diverse fields. NGS is moving toward “active” monumentation via the CORS network and its online positioning user service (OPUS). This is a departure from the traditional delivery of precise geodetic control from passive monumentation. Currently, network solutions for RT positioning are sweeping across the United States. The cost to benefit ratio and ease of use are two main factors driving this rapid growth. As can be seen from the following list, RTN administrators span a wide sector of all GNSS users. Some examples of the RTN administrators that are part of this rapidly expanding GNSS application are: state departments of transportation (DOT), value-added GNSS vendors, GNSS manufacturers, spatial reference centers, geodetic

surveys, academic institutions, scientific groups, county governments, city governments, private surveying and engineering companies and agricultural cooperatives.

**Benefits to the user of an RTN over classical RT positioning include:**

1. No user base station is necessary. Therefore, there are no security issues with the base, no control recovery is necessary to establish its position, and the user needs only half the equipment to produce RT work. Additionally, there is no lost time setting up and breaking down the base station equipment and radio.
2. The first order ppm error is eliminated (or drastically reduced), because ionospheric, tropospheric and orbital errors are interpolated to the site of the rover.
3. The network can be positioned to be aligned with the *NSRS* with high accuracy. The users will then be collecting positional data that will fit together seamlessly. This is important to all users of geospatial data, such as GIS professionals who may deal with such regional issues as emergency management and security issues.
4. Datum readjustments or changes can be done transparently to the user with no post-campaign work. New datum adjustments to NAD 83, or even transformations to another geodetic reference frame, such as the International Terrestrial Reference Frame (ITRF), are done at the network level and are broadcast to the users.
5. With some business models, the user can share in the network profits by installing a network reference station, and thereby getting a share of the subscription fees imposed upon other network users.
6. Different formats and accuracies are readily available. GIS data, environmental resource data, mapping grade data, etc. can be collected with one- or two-foot accuracy, while surveyors and engineers can access the network with centimeter-level accuracy. RTCM, CMR+ and other binary formats can be user selected.
7. The RTN can be quality checked and monitored in relation to the *NSRS* using *NGS* programs, such as OPUS and TEQC from UNAVCO.

**Drawbacks to the user of an RTN compared to classical RT positioning include:**

1. Network subscription fees. These may be prohibitive for small companies.
2. Limited wireless data access.
3. Interpolation issues. Network spacing, communication and error modeling must be handled optimally.
4. Work outside the network envelope (extrapolation of corrections) degrades accuracy.
5. The network solution may not fit to local control. Localization or control network adjustments may be necessary.
6. Coordinate metadata. Does the network datum adjustment and epoch meet the user's requirements?
7. Can all GNSS manufacturers' equipment be used, and will different gear produce the same results?
8. Will overlapping RTN produce homogenous coordinates?

NGS has an important role to play in this new positioning solution, both in providing support for these networks, as well as protecting the public interest. In addition, NGS plans to encourage RTN to successfully align to the NSRS within a certain tolerance (to be determined) by connections to the CORS network. Following this document, NGS will develop user guidelines and administrative guidelines for RTN in an effort to keep the produced positions homogenous and accurate for all levels of geospatial professionals.

### **VIII. Best Methods Summary**

The following are taken from the highlighted, underlined or otherwise summarized recommendations found throughout the document. It is felt that an easily printable composite of the best methods would provide a very useable guide for quick reference. However, for the proper knowledge of the many variables and influences on accurate RT positioning, the background information throughout the document should be digested to help the user collect reliable data.

- RT positioning of important data points cannot be done reliably without some form of redundancy.
- Redundancy is critical for important point positions using RT.
- Regardless of the type of external battery used, it should supply at least 12 volts and

should be fully charged. An underpowered battery can severely limit communication range.

- The base broadcast radio antenna should be raised to the maximum height possible.
- Rather than communicating with a dynamic address, as is the case in many internet scenarios, static IP addresses provide a reliable connection and are the recommended communication link configuration.
- Adjust the base and rover circular level vial before every campaign.
- As a good practice, or if the circular level vial is not adjusted, it is still possible to eliminate the possible plumbing error by taking two observations on a point, with the rover pole rotated 180° between each location.
- Clock and hardware errors are eliminated with differencing, while some modeling can be done for the ionospheric and tropospheric errors. Generally, the conditions are considered to cancel as they are relative to both base and rover receivers.

**Note:** 1 nanosecond of time error translates to 30 cm in range error.

- It is possible to perform an accurate RT session from an autonomous-positioned base station point, if the correct position can be introduced to the project in the data collector or in the office software later.
- In fact, it is much better to establish a new, completely open sky view site for the base than it is to try to occupy an existing reliable, well known monument with a somewhat obscured sky view.

During an interval encompassing the solar maximum, users can expect inability to initialize, loss of satellite communications, loss of wireless connections and radio blackouts, perhaps in random areas and time spans.

<http://www.sec.noaa.gov/NOAAscales/index.html#SolarRadiationStorms>

**Recommendations:** Do not try to perform RT during level G3 – G5 storm events.

**Recommendations:** Do not try to perform RT during level S4 – S5 storm events.

**Recommendations:** Do not try to perform RT during level R3 – R5 storm events. Be aware of possible radio problems at level R2 storm events.

- Unlike networked solutions for RT positioning, in classical (single base) RT positioning, there is minimal atmospheric modeling, because it is assumed both the base station and the rover are experiencing nearly identical atmospheric conditions.
- The single most important guideline to remember about the weather with RT positioning is to never perform RT in obviously different conditions from base to rover.
- It is helpful to partially mitigate the worst effects of atmospheric delay and refraction by setting an elevation mask (cut-off angle) of  $10^{\circ}$ -  $15^{\circ}$  to block the lower satellites signals with the longest run through the atmosphere. A  $10^{\circ}$  mask is recommended.
- The actual data collection or point stake out is displayed in the data collector based on a system precision showing the spread of the results (RMS) at a certain confidence level and the calculated 2-D and height (horizontal and vertical) solution relative to the base station in the user's reference frame.
- Therefore, to get a sense of the accuracy achieved, it is recommended the user's survey be based on proven control monumentation with a high degree of integrity, the data precision is monitored as the work proceeds, points with known values are checked before, during and after each RT session, and redundant locations are taken on each important point.
- When viewing the RMS on the data collector screen, the user should be aware of the confidence level. Some displays show a 68% confidence for the horizontal and vertical precision.
- Areas with probable multipath conditions should not be used for RT positioned control sites, especially not for a base station position. These sites include locations under, or very near, tree canopy, structures within 30 m that are over the height of the antenna, nearby vehicles and nearby metal objects, abutting large water bodies, and nearby signs.
- RT localizations allow the user to transform the coordinates of the control monumentation, positioned with their RT-derived positions in the WGS 84 datum, to the user datum (even if it's assumed), as realized by the user's coordinates on the monuments.
- To have confidence in a site localization, the project site must be surrounded by at least four trusted vertical control monuments and four trusted horizontal control monuments, which, to the greatest extent possible, form a rectangle.
- It is critical all project work is done using the same correct and verified calibration.

- Different calibrations can result in substantially different position coordinates. If the site localization is changed in the office, resulting in new coordinates on all located points, the new localization information must be uploaded to the data collector before any further field work is done for that project. The user must be aware of the solution state and should wait until the solution is displayed as fixed before taking RT observations.
- For best vertical results, it is recommended to apply the current hybrid geoid model in addition to a localization to the vertical control.
- To collect important positional data, the communication link should be continuous and the GNSS solution should become fixed in a “normal” amount of time and should remain fixed for the duration of the data collection at the point.
- Before beginning new point data collection, a check shot should always be taken on a known point.
- To collect important positional data, known and trusted points should be checked with the same initialization as subsequent points to be collected.

It is important to know what accuracy is needed before performing the RT field work.

ACCURACY CLASS SUMMARY TABLE				
	CLASS RT1	CLASS RT2	CLASS RT3	CLASS RT4
ACCURACY (TO BASE)	0.015 HORIZONTAL, 0.025 VERTICAL	0.025 HORIZONTAL, 0.04 VERTICAL	0.05 HORIZONTAL, 0.06 VERTICAL	0.15 HORIZONTAL, 0.25 VERTICAL
REDUNDANCY	≥ 2 LOCATIONS, 4-HOUR DIFFERENTIAL	≥ 2 LOCATIONS, 4-HOUR DIFFERENTIAL	NONE	NONE
BASE STATIONS	≥ 2, IN CALIBRATION PROJECT CONTROL	RECOMMEND 2 IN CALIBRATION	≥ 1, IN CALIBRATION	≥ 1, IN CALIBRATION RECOMMENDED
PDOP	≤ 2.0	≤ 3.0	≤ 4.0	≤ 6.0
RMS	≤ 0.01 M	≤ 0.015 M	≤ 0.03 M	≤ 0.05 M
COLLECTION INTERVAL	1 SECOND FOR 3-MINUTES	5 SECONDS FOR 1-MINUTE	1 SECOND FOR 15 SECONDS	1 SECOND FOR 10 SECONDS
SATELLITES	≥ 7	≥ 6	≥ 5	≥ 5
BASELINE DISTANCE	≤ 10 KM	≤ 15 KM	≤ 20 KM	ANY WITH FIXED SOLUTION
TYPICAL APPLICATIONS	PROJECT CONTROL CONSTRUCTION CONTROL POINTS CHECK ON TRAVERSE, LEVELS SCIENTIFIC STUDIES PAVING STAKE OUT	DENSIFICATION CONTROL TOPOGRAPHIC CONTROL PHOTOPOINTS UTILITY STAKE OUT	TOPOGRAPHY CROSS SECTIONS AGRICULTURE ROAD GRADING SITE GRADING	SITE GRADING WETLANDS GIS POPULATION MAPPING ENVIRONMENTAL

**For Accuracy Classes RT1 and RT2:**

If a calibration has been performed, the base station must be inside the calibration envelope and must be connected to the nearest calibration control monument by a maximum of 1 cm + 1 ppm horizontal and 2 cm + 1 ppm vertical tolerances at the 95 percent confidence level.

**For Accuracy Classes RT3 and RT4:**

If a calibration has been performed, the base station must be inside the calibration envelope and should be connected to the nearest calibration control monument at the accuracy level of the survey.

If the data are collected with covariance matrices and there is redundancy or connecting points, a post-campaign adjustment can also be performed (although at typically less accuracy than with static network observations).

The following are all terms that must be understood and/or monitored by RTK field technicians. Look for these terms and concepts in the guidelines; knowledge of these is necessary for expertise at the rover:

- DOP varieties
- Multipath
- Baseline RMS
- Number of satellites
- Elevation mask (or cut-off angle)
- Base accuracy-datum level, local level
- Base security
- Redundancy, redundancy, redundancy
- PPM—iono, tropo models, orbit errors
- Space weather- “G”, “S”, “R” levels
- Geoid quality
- Constraining passive monuments
- Bubble adjustment
- Latency, update rate
- Fixed and float solutions
- Accuracy versus Precision
- Signal to Noise Ratio (S/N or  $C/N_0$ )
- Elevation Mask
- Geoid Model
- Part Per Million (PPM) Error
- UHF, spread spectrum Radio Communication
- CDMA/SIM/Cellular TCP/IP Communication

Additionally, the following concepts should be understood. Please see the RT positioning glossary (herein) for brief definitions:

- Carrier Phase/Code Phase
- WGS 84, ITRS versus NAD 83
- GPS and GLONASS Constellations

RT positioning yields coordinates from the field work performed, but little else in the way of information on the equipment used and how the work was performed. The responsible geospatial professional must put procedures in place to ensure adequate *metadata* (data about data) is recorded.

**Quick Field Summary:**

- Set the base at a wide-open site.
- Set rover elevation mask between 10° & 15.°
- The more satellites, the better.
- The lower the PDOP, the better.
- The more redundancy, the better.
- Beware multipath.
- Beware long initialization times.
- Beware antenna height blunders.
- Survey with “fixed” solutions only.
- Always check known points before, during and after new location sessions.
- Keep equipment adjusted for highest accuracy.
- Communication should be continuous while locating a point.
- Know the precision displayed in the data collector. It might be at the 68 percent level (or one sigma), which is only about half the error spread to achieve 95 percent confidence.
- Have back-up batteries & cables.
- RT doesn't like tree canopy or tall buildings.

**Links:**

NGS: <http://geodesy.noaa.gov>

USCG NANU: <http://navcen.uscg.gov/?pageName=listServerForm>

SWPC: <http://www.swpc.noaa.gov/>

NGS' Geodetic Glossary for terminology used in this document:

[http://www.ngs.noaa.gov/CORS-Proxy/Glossary/xml/NGS\\_Glossary.xml](http://www.ngs.noaa.gov/CORS-Proxy/Glossary/xml/NGS_Glossary.xml)

## References

1. Ahn, Yong Won (M.Sc. thesis), (2005), Analysis of NGS CORS Network for GPS RTK Performance Using External NOAA Tropospheric Corrections Integrated with a Multiple Reference Station Approach, *UCGE Report 20211*.
2. Beutler, G., Bauersima, I., Gurtner, W., Rothacher, M., Schildknecht, T. & Geiger, A., (1989). Atmospheric refraction and other important biases in GPS carrier phase observations. In monograph 12, *Atmospheric Effects on Geodetic Space Measurements*, F.K.Brunner (ed.), School of Geomatic Engineering (formerly Surveying), The University of New South Wales, 15-44.
3. Caltrans/Division of Right of Way and Land Surveys, Surveys Manual, (2006).webpage  
[http://www.dot.ca.gov/hq/row/landsurveys/SurveysManual/Manual\\_TOC.html](http://www.dot.ca.gov/hq/row/landsurveys/SurveysManual/Manual_TOC.html)
4. Caroline Erickson (M.Sc. thesis),(1992), Investigations of C/A Code and Carrier Measurements and Techniques for Rapid Static GPS Surveys, *UCGE Report No. 20044*.  
<http://www.geomatics.ucalgary.ca/Papers/Thesis/GL/92.20044>
5. Dennis, Michael L., (2008), “Ground Truth- Design and Documentation of Low Distortion Projections for Surveying and GIS”, Arizona Professional Land Surveyors 2008 workshop paper.
6. Dao, Thi Hong Diep, (2005). Performance Evaluation of Multiple Reference Station GPS RTK for a Medium Scale Network. *UCGE Report 20214*.  
<http://www.geomatics.ucalgary.ca/links/GradTheses.html>
7. Eckl, M.C., Snay, R.A., Soler, T., Cline, M.W., & Mader, G.L.,(2002), Accuracy of GPS Derived Relative Positions As a Function of Interstation Distance and Observing Station Duration. *Journal of Geodesy*, 75 (12):pp 633-640.
8. Edwards, S., Clarke, P., Goebell, S., Penna, N, (2008), An Examination of Commercial Network RTK GPS Services in Great Britain. School of Civil Engineering and Geosciences Newcastle University, Newcastle upon Tyne NE1 7RU
9. Gutman, S., T. Fuller-Rowell and D. Robinson, (2003). Using NOAA Atmospheric Models to Improve Ionospheric and Tropospheric Corrections, *U.S. Coast Guard Differential GPS Symposium*, June 2003, Portsmouth, U.S.A.  
[http://www.gpsmet.noaa.gov/jsp/downloads/NOAA\\_Atmospheric\\_Corrections.ppt](http://www.gpsmet.noaa.gov/jsp/downloads/NOAA_Atmospheric_Corrections.ppt).

10. International Organization for Standardization (ISO) TC 172/SC 6, (2008). Optics And Optical Instruments- Field Procedures For Testing Geodetic And Surveying Instruments - Part 8: GNSS Field Measurement Systems In Real-Time Kinematic (RTK),  
[http://www.iso.org/iso/iso\\_catalogue/catalogue\\_tc/catalogue\\_detail.htm?csnumber=42213](http://www.iso.org/iso/iso_catalogue/catalogue_tc/catalogue_detail.htm?csnumber=42213)
11. Landau, H. and Euler, H. J., (1992), On-The-Fly Ambiguity Resolution for Precise Differential Positioning, *ION GPS-92 Proceedings*, Albuquerque, New Mexico, pp. 607-613.
12. Langley, R.B., (1997), GPS Receiver System Noise, *GPS World*, Vol. 8, No. 6, pp.40-45
13. Leick, A., (2004), Wiley, GPS Satellite Surveying, Third Edition
14. Mader, G. (1990): Ambiguity Function Techniques for GPS Phase Initialization and Kinematic Solutions. *Proceedings of the Second International Symposium on Precise Positioning with the Global Positioning System*, Ottawa, Canada, Sept. 1990.
15. Meyer, T.H., Bean, J.E., Ferguson, C.R. & Naismith, J.M., (2002), The Effect of Broadleaf Canopies on Survey-Grade Horizontal GPS/GLONASS Measurements, *Surveying and Land Information Science* 62(4), 215–224.
16. Meyer, T. H., Hiscox, A.,(2005), Position Errors Caused By GPS Height of Instrument Blunders, webpage [http://digitalcommons.uconn.edu/thmeyer\\_articles/4/](http://digitalcommons.uconn.edu/thmeyer_articles/4/)
17. New York State Department of Transportation/Land Surveying section, (2005), Land Surveying Standards and Procedures Manual. webpage <https://www.nysdot.gov/portal/page/portal/divisions/engineering/design/design-services/land-survey/standards-procedures>
18. NOAA (2005) Space Weather Prediction Center. webpage. <http://www.sec.noaa.gov>
19. Remondi, B. W., (1984), Using the Global Positioning System (GPS) phase observable for relative geodesy: modeling, processing, and results, *PhD Thesis*, University of Texas at Austin.
20. Remondi, B. W., Performing Centimeter-Level Surveys in Seconds with GPS Carrier Phase: Initial Results, *Journal of The Institute of Navigation*, Vol. 32, No. 4, Winter 1985-6
21. Rizos, C., (1999), Principles and Practice of GPS Surveying, accessed via the web, July 2008: [http://www.gmat.unsw.edu.au/snap/gps/gps\\_survey/principles\\_gps.htm](http://www.gmat.unsw.edu.au/snap/gps/gps_survey/principles_gps.htm)

22. Yang X., Brock R., RDOP Surface for GPS Relative Positioning, United States Patent 6057800, issued May 2, 2000, web page <http://www.patentstorm.us/patents/6057800-fulltext.html>
23. Zilkoski, D.; D'onofrio, J.; Frakes, S. (1997). *NOAA Technical Memorandum NOS-NGS-58 Guidelines for Establishing GPS-Derived Ellipsoid Heights (Standards: 2 cm and 5cm)* Version 4.3, November 1997, webpage: [http://www.ngs.noaa.gov/PUBS\\_LIB/NGS-58.html](http://www.ngs.noaa.gov/PUBS_LIB/NGS-58.html)
24. Zilkoski, D.; Carlson, E.; Smith, C., (2005). *Draft Guidelines for Establishing GPS-Derived Orthometric Heights (Standards: 2 cm and 5 cm) Version 1.4.* webpage: [http://www.ngs.noaa.gov/PUBS\\_LIB/NGS592008069FINAL2.pdf](http://www.ngs.noaa.gov/PUBS_LIB/NGS592008069FINAL2.pdf)

## Appendix A

### Differencing and Ambiguity Resolution

This section graphically depicts the differencing sequence as it progresses through single and double differencing. Triple differencing is used to check for cycle slips and top narrow the search radius for ambiguity resolution.

First given is the undifferenced observable equation in cycles delineating the error sources and unknowns. Note that after differencing and ambiguity resolution, the multipath error is still unmodeled and remains in the positional error. The observable equations are solved for both L<sub>1</sub> and L<sub>2</sub> frequencies to each acquired satellite. *See Leick, (2004)*

#### Undifferenced Carrier Phase Observable $\varphi_k^p(t)$

$$\varphi_k^p(t) = \frac{f}{c} \rho_k^p(t) - f dt_k(t) + f dt^p(t) + N_k^p - I_{k,\varphi}^p(t) + \frac{f}{c} T_k^p(t) + d_{k,\varphi}(t) + d_{k,\varphi}^p(t) + d_\varphi^p(t) + s_\varphi$$

Superscripts refer to the satellite, subscripts refer to ground station

$\varphi$ : Carrier phase observable in cycles  $\varphi_k^p$  refers to the carrier phase observable from SV p to Station k.

$f$ : Carrier frequency

$c$ : Speed of light **( $f/c$  for L1= 5.255 CYCLES PER METER)**

$\rho(t)$ : The topocentric range  $\rho_k^p$  is the range from SV p to Station k.

$dt_k(t)$ : Receiver clock bias as a function of time

$dt^p(t)$ : SV clock error as a function of time

$N_k^p$ : The integer ambiguity from SV p to Station k

$I_k^p(t)$ : Ionospheric advance  $I_{k,\varphi}^p$  is the Ionospheric advance from SV p to Station k in cycles

$T(t)$ : Tropospheric delay  $T_k^p$  is the tropospheric delay from SV p to Station k

$d_{k,p}(t)$ : Receiver hardware delays in cycles as a function of time

$d_{k,p}^m(t)$ : Multipath in cycles as a function of time

$d_p^s(t)$ : Satellite hardware delays in cycles as a function of time

$\epsilon_p$ : Measurement noise in cycles

$\varphi_k^p$  is the actual phase observable recorded in the receiver.

The terms to the right of the equal sign model various components that make up the observable.  $N_k^p$  is the initial integer count of the number of cycles from SV p to Station k. This is also referred to as the integer ambiguity. Unlike the other modeled terms to the right of the

equal sign, it is not a function of time, as long as the receiver maintains lock on the SV signal this number will not change.

When a receiver locks onto a signal from the GPS satellite, it continuously monitors the satellite transmission. At predetermined epochs, the receiver records the data at that epoch. The frequency with which the receiver records data is the data sampling rate. The data sampling rate is frequently incorrectly described as "epochs". For example, it is often, "Data was collected at

30 second epochs." The correct terminology is, "Data was collected with a data sampling rate of

30 seconds." An *epoch* is a particular instant in time. The time between epochs is an *interval*.

## Single-Difference

A **single difference** is the difference between two **undifferenced** observables for the same satellite at the same epoch.

$\varphi_k^p(t) = \varphi_k^p(t) - \varphi_m^p(t)$  is the single difference between SV p and Stations k and m at epoch t.

$$\begin{aligned} \varphi_{km}^p(t) &= \varphi_k^p(t) - \varphi_m^p(t) \\ &= \frac{f}{c} \rho_k^p(t) - f dt_k(t) + f dt^p(t) + N_k^p - I_{k,\varphi}^p(t) + \frac{f}{c} T_k^p(t) + d_{k,\varphi}^p(t) + d_{k,\varphi}^p(t) + d_\varphi^p(t) + s_{k,\varphi}^p \\ &\quad - \left( \frac{f}{c} \rho_m^p(t) - f dt_m(t) + f dt^p(t) + N_m^p - I_{m,\varphi}^p(t) + \frac{f}{c} T_m^p(t) + d_{m,\varphi}^p(t) + d_{m,\varphi}^p(t) + d_\varphi^p(t) + s_{m,\varphi}^p \right) \\ &= \frac{f}{c} (\rho_k^p(t) - \rho_m^p(t)) - f (dt_k(t) - dt_m(t)) + f (\cancel{dt^p(t)} - \cancel{dt^p(t)}) + (N_k^p - N_m^p) - (I_{k,\varphi}^p(t) - I_{m,\varphi}^p(t)) \\ &\quad + \frac{f}{c} (T_k^p(t) - T_m^p(t)) + (d_{k,\varphi}^p(t) - d_{m,\varphi}^p(t)) + (d_{k,\varphi}^p(t) - d_{m,\varphi}^p(t)) + (\cancel{d_\varphi^p(t)} - \cancel{d_\varphi^p(t)}) + (s_{k,\varphi}^p - s_{m,\varphi}^p) \\ &= \frac{f}{c} (\rho_k^p(t) - \rho_m^p(t)) - f (dt_k(t) - dt_m(t)) + N_{km}^p - I_{km,\varphi}^p + \frac{f}{c} T_{km}^p(t) + d_{km,\varphi}^p(t) + d_{km,\varphi}^p(t) + s_{km,\varphi}^p \end{aligned}$$

The satellite clock errors and satellite hardware delays cancel.

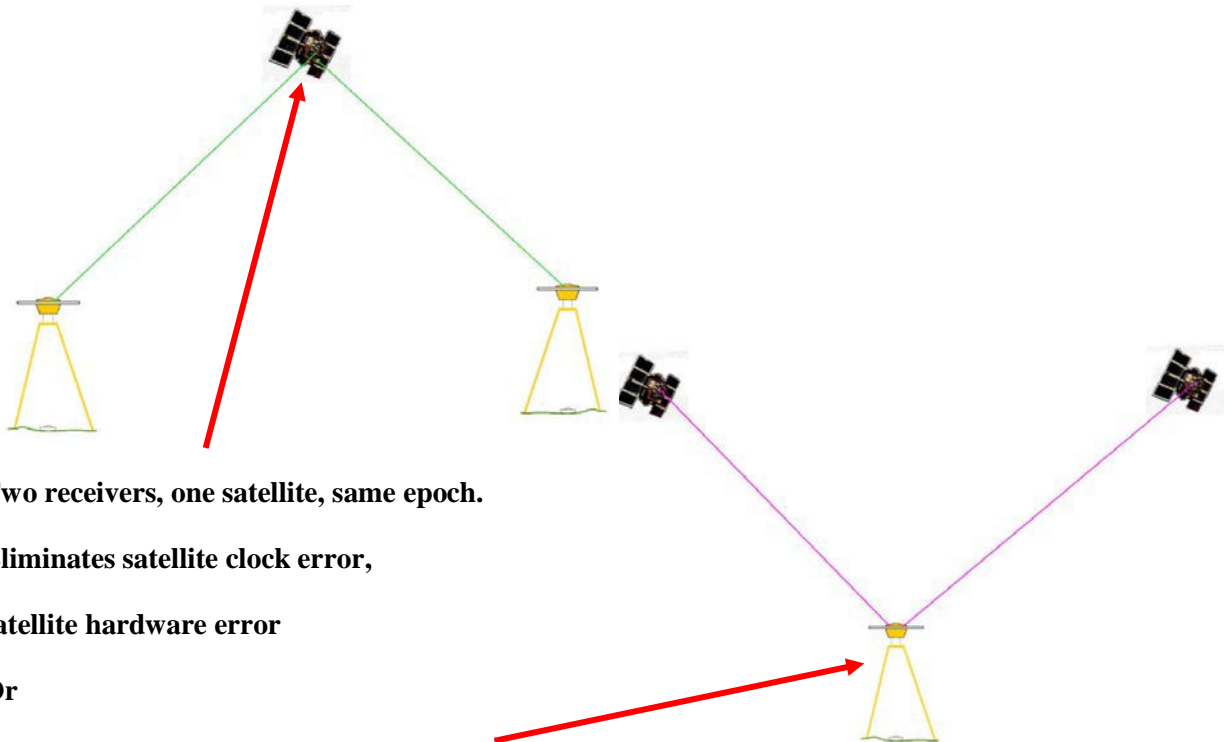

Two receivers, one satellite, same epoch.

Eliminates satellite clock error,  
satellite hardware error

Or

Two satellites, one receiver same epoch,

eliminates receiver clock and hardware

error.

### Double-Differenced Phase Solution

$\varphi_{km}^{pq}(t) = \varphi_{km}^p(t) - \varphi_{km}^q(t)$  is the **double difference** observable between SV p and q and Stations k and m at epoch t.

$$\begin{aligned} \varphi_{km}^{pq}(t) &= \varphi_{km}^p(t) - \varphi_{km}^q(t) \\ &= \frac{f}{c} (\rho_k^p(t) - \rho_m^p(t)) - f \Delta t_{km}(t) + N_{km}^p - I_{km,p}^p(t) + \frac{f}{c} T_{km}^p(t) + d_{km,\phi}^p(t) + \varepsilon_{km,\phi}^p \\ &\quad - \left( \frac{f}{c} (\rho_k^q(t) - \rho_m^q(t)) - f \Delta t_{km}(t) + N_{km}^q - I_{km,\phi}^q(t) + \frac{f}{c} T_{km}^q(t) + d_{km,\phi}^q(t) + \varepsilon_{km,\phi}^q \right) \\ &= \frac{f}{c} (\rho_k^p(t) - \rho_m^p(t) - \rho_k^q(t) + \rho_m^q(t)) - \left[ \cancel{d_{km,\phi}^p(t)} - \cancel{d_{km,\phi}^q(t)} \right] + (N_{km}^p - N_{km}^q) - (I_{km,\phi}^p(t) - I_{km,\phi}^q(t)) \\ &\quad + \frac{f}{c} (T_{km}^p(t) - T_{km}^q(t)) + \left[ \cancel{d_{km,\phi}^p(t)} - \cancel{d_{km,\phi}^q(t)} \right] + (d_{km,\phi}^p(t) - d_{km,\phi}^q(t)) + (\varepsilon_{km,\phi}^p - \varepsilon_{km,\phi}^q) \\ &= \frac{f}{c} (\rho_k^p(t) - \rho_m^p(t) - \rho_k^q(t) + \rho_m^q(t)) + N_{km}^{pq} - (I_{km,\phi}^{pq}) + \frac{f}{c} (T_{km}^{pq}(t)) + d_{km,\phi}^{pq}(t) + \varepsilon_{km}^{pq} \end{aligned}$$

Now the receiver clock errors and hardware delays cancel.

DOUBLE DIFFERENCE – 2 SVNS / 2 RECEIVERS / 1 EPOCH

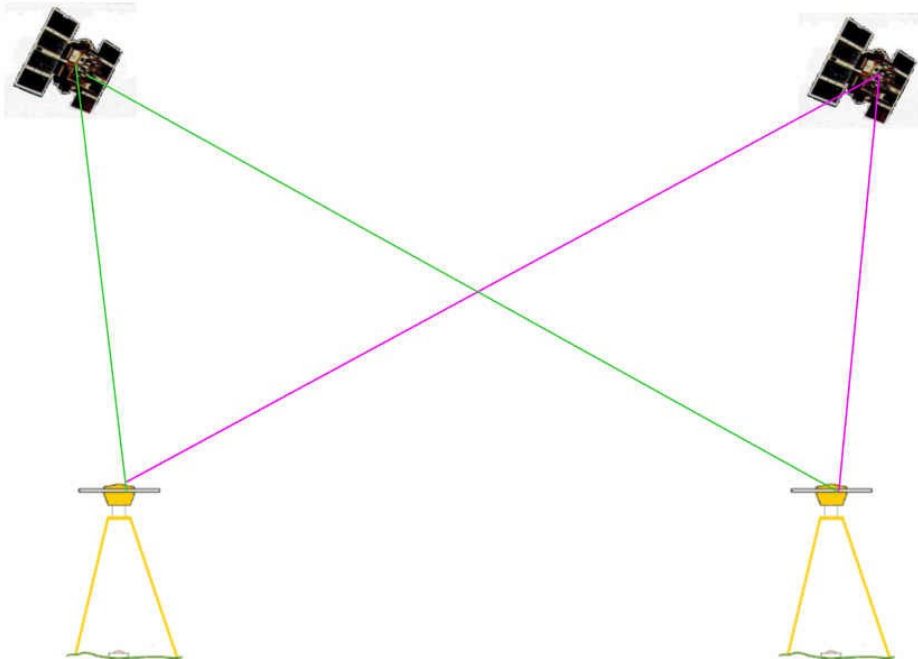

Double differencing: two receivers, two satellites, same epoch (two Single Differences). Eliminates receiver clock error, receiver hardware error, reduces other errors.

### Triple-Differenced Phase Solution

A **triple difference** observable is the difference between two **double difference** observables for successive epochs.

$\varphi_{km}^{pq}(t_2, t_1) = \varphi_{km}^{pq}(t_2) - \varphi_{km}^{pq}(t_1)$  is the triple difference between SV p and q and Stations k and m at epoch  $t_2$  and epoch  $t_1$ .

$$\varphi_{km}^{pq}(t_1) = \frac{f}{c} (\rho_k^p(t_1) - \rho_m^p(t_1) - \rho_k^q(t_1) + \rho_m^q(t_1)) + N_{km}^{pq}$$

$$\varphi_{km}^{pq}(t_2) = \frac{f}{c} (\rho_k^p(t_2) - \rho_m^p(t_2) - \rho_k^q(t_2) + \rho_m^q(t_2)) + N_{km}^{pq}$$

$$\begin{aligned} \varphi_{km}^{pq}(t_2, t_1) &= \frac{f}{c} (\rho_k^p(t_2) - \rho_m^p(t_2) - \rho_k^q(t_2) + \rho_m^q(t_2)) + N_{km}^{pq} \\ &\quad - \left( \frac{f}{c} (\rho_k^p(t_1) - \rho_m^p(t_1) - \rho_k^q(t_1) + \rho_m^q(t_1)) + N_{km}^{pq} \right) \\ &= \frac{f}{c} (\rho_k^p(t_2) - \rho_k^p(t_1) - \rho_m^p(t_2) + \rho_m^p(t_1) - \rho_k^q(t_2) + \rho_k^q(t_1) + \rho_m^q(t_2) - \rho_m^q(t_1)) \\ &\quad + \cancel{N_{km}^{pq}} - \cancel{N_{km}^{pq}} \leftarrow \text{Cancels Double Difference integer cycles} \\ &= \frac{f}{c} (\rho_k^p(t_2) - \rho_k^p(t_1) - \rho_m^p(t_2) + \rho_m^p(t_1) - \rho_k^q(t_2) + \rho_k^q(t_1) + \rho_m^q(t_2) - \rho_m^q(t_1)) \end{aligned}$$

TRIPLE DIFFERENCE – DOUBLE DIFFERENCES ON 2 EPOCHS

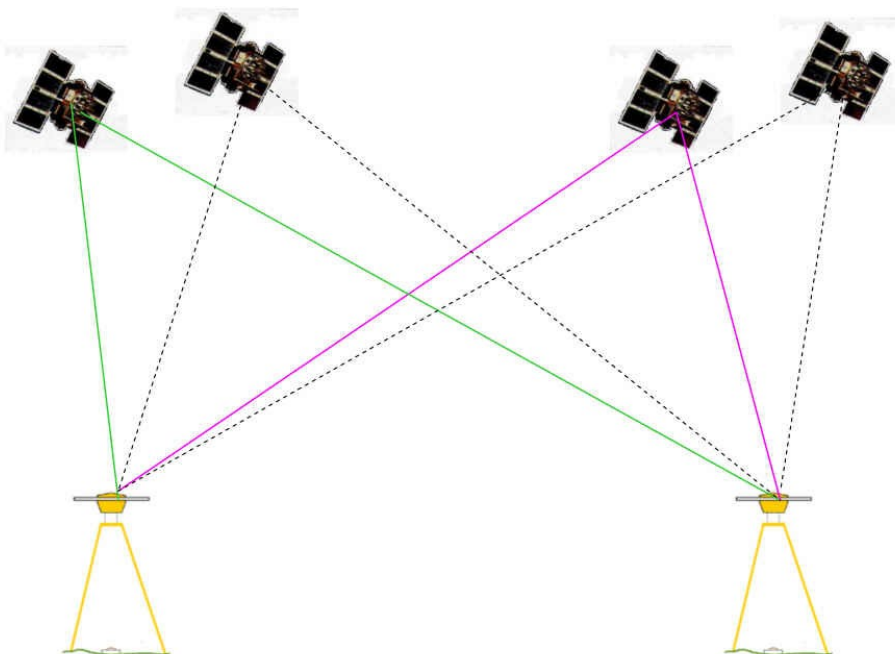

If the receiver retains lock between epochs, the double difference ambiguity remains the same for each epoch and therefore will cancel out in the triple difference equation. If the receiver loses lock, the triple difference solution that contains that loss of lock will show as an outlier and therefore will show the cycle slip during processing.

## RESULTING DIFFERENCED PHASE OBSERVABLE (CYCLES)

$$\varphi_k^r(t) = \frac{f}{c} \varphi_k^s(t) - \lambda \Delta N_k(t) - \lambda \Delta N_{k,r}^s(t) - N_{k,r}^s - I_{k,r}^s(t) + \frac{f}{c} T_k^s(t) + a_{k,r}^s(t) + d_{k,r}^s(t) + s_{\varphi}$$

Superscripts refer to the satellite, subscripts refer to ground station

**LEAVES MULTIPATH,  
MEASUREMENT NOISE  
& RANGE TO  
SATELLITE**

**ASSUMED THE SAME FOR  
ROVER & BASE**

**Number of Cycles x wave length = distance to satellite.**

Variance-covariance matrices are formed from the double differenced ambiguities. The best candidates are established for the integer cycle solution. Pseudorange measurements and frequency combinations such as wide laning and narrow laning and Kalman filtering are some methods that are used to solve the ambiguities through iterative least squares solutions.

Some factors influencing the reliability of Ambiguity Resolutions are:

- Baseline Length
- GDOP - satellite-receiver geometry
- Residual Atmospheric and orbit errors
- Multipath
- Cycle slips
- Search strategy algorithms
- Rising/setting satellites

- Round off integers

Statistically, the ratio of the best to next best solution is constantly monitored in conjunction with change or increase in the RMS. This then gives assurance of the correct ambiguity resolution as the session proceeds after initialization to a fixed solution. Most major GNSS hardware/software manufacturers give their ambiguity resolution confidence at 99.9 percent.

## Appendix B

### Adjusting the Circular Level Vial

From SECO ( [http://www.surveying.com/tech\\_tips/details.asp?techTipNo=13](http://www.surveying.com/tech_tips/details.asp?techTipNo=13) ):

#### Adjustment Of The Circular Vial:

1. Set up and center bubble as precisely as possible.
2. Rotate center pole 180 degrees. If any part of the bubble goes out of the black circle adjustment is necessary.
3. Move quick release legs until bubble is half way between position one and position two.
4. With a 2.5 mm allen wrench turn adjusting screws until bubble is centered. Recommended procedure is to tighten the screw that is most in line with the bubble. Caution: very small movements work best.
5. Repeat until bubble stays entirely within circle.

A rover pole with an adjusted **standard 40-minute vial** located about midpoint of the length should introduce a maximum leveling error of no more than 2.5 mm (less than 0.01 feet). It should be noted that 10 minute vials are available.

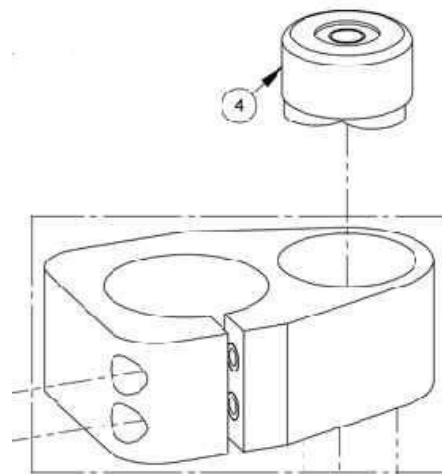

Diagram C-1 - Typical circular vial assembly for the Rover pole